



Spare Parts List  
Ersatzteilliste  
Liste de pièces détachées  
Lista de piezas de repuesto

2011-03

PRM0700 (2011)



PRM0700 (2011-03) (D, GB, F, E)

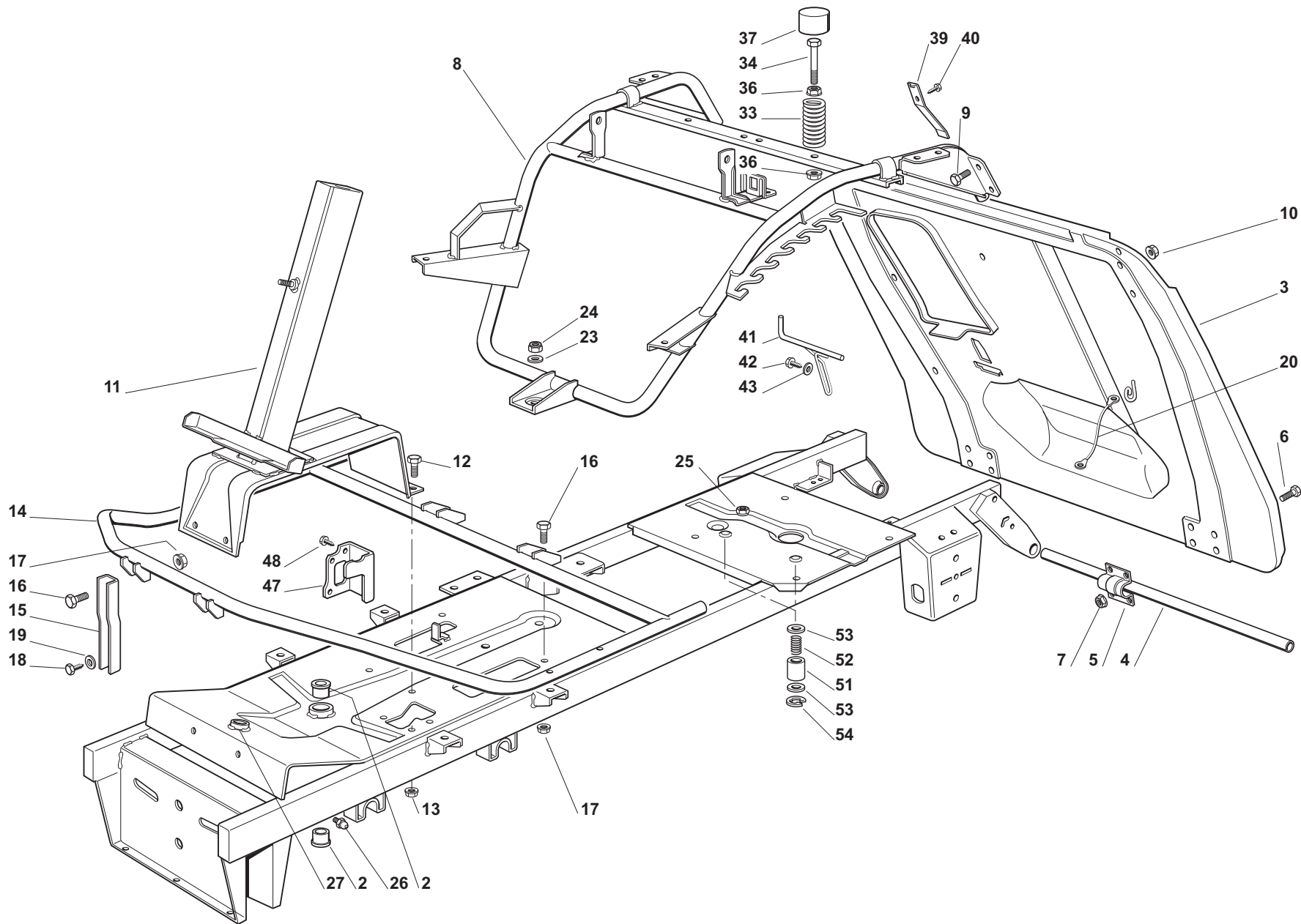

PRM0700 (2011)

1

 RAHMENSATZ  
 CHASSIS  
 CHASSIS  
 CHASIS

Seite / Page	Pos.	PRM0700 (2011)	Teil-Nr. Part No. No. de pièce No. de pieza	Hinweise Notes Renseign. Nota	Bezeichnung	Spezifikation Specification	Description	Désignation	Denominación
1	2	2	664 034 002		BUCHSE		BUSH	DOUILLE	CASQUILLO
1	3	1	664 545 057		PLATTE		PLATE	PLAQUE	PLACA
1	4	1	664 037 000		BOLZEN		PIN	PIVOT	PIVOTE
1	5	2	664 547 012		PLATTE		PLATE	PLAQUE	PLACA
1	6	8	664 791 200		SCHRAUBE		SCREW	VIS	TORNILLO
1	7	8	664 292 102		MUTTER		NUT	ECROU	TUERCA
1	8	1	664 801 127		RAHMENSATZ		CHASSIS	CHASSIS	CHASIS
1	9	4	664 792 611		SCHRAUBE		SCREW	VIS	TORNILLO
1	10	4	664 293 201		MUTTER		NUT	ECROU	TUERCA
1	11	1	664 783 027		HALTER		SUPPORT	SUPPORT	SOPORTE
1	12	4	664 792 611		SCHRAUBE		SCREW	VIS	TORNILLO
1	13	4	664 293 201		MUTTER		NUT	ECROU	TUERCA
1	14	1	664 801 107		FUSSBRETTALTER		FOOTBOARD SUPPORT	SUPPORT MARCHEPIED	SOPORTE
1	15	2	664 787 025		HALTER		SUPPORT	SUPPORT	SOPORTE
1	16	4	664 792 611		SCHRAUBE		SCREW	VIS	TORNILLO
1	17	4	664 293 201		MUTTER		NUT	ECROU	TUERCA
1	18	2	664 734 995		SCHRAUBE		SCREW	VIS	TORNILLO
1	19	2	664 521 331		SCHEIBE		WASHER	RONDELLE	ARANDELA
1	20	1	664 040 300		SEIL		CORD	CORDE	CUERDA
1	23	1	664 523 060		SCHEIBE		WASHER	RONDELLE	ARANDELA
1	24	1	664 155 000		MUTTER		NUT	ECROU	TUERCA
1	25	1	664 500 090		MUTTER		NUT	ECROU	TUERCA
1	26	1	664 379 511		FETTBUCHSE		GREASE DISPENSER	GRAISSEUR	CASQUILLO DE ENGRASE
1	27	1	664 034 001		BUCHSE		BUSH	DOUILLE	CASQUILLO
1	33	2	664 430 575		FEDER		SPRING	RESSORT	MUELLE
1	34	2	664 943 050		SCHRAUBE		SCREW	VIS	TORNILLO
1	36	4	664 293 201		MUTTER		NUT	ECROU	TUERCA
1	37	2	664 122 000		SCHUTZKASTEN		HOOD	PROTECTEUR	CUBIERTA
1	39	1	664 430 554		FEDER		SPRING	RESSORT	MUELLE
1	40	1	664 735 110		SCHRAUBE		SCREW	VIS	TORNILLO
1	41	1	664 294 001		FÜHRUNG		GUIDE	GUIDE	GUÍA
1	42	1	664 735 120		SCHRAUBE		SCREW	VIS	TORNILLO
1	43	1	664 523 040		SCHEIBE		WASHER	RONDELLE	ARANDELA
1	47	1	664 772 095		HALTER		CLAMP	ETRIER	SOPORTE
1	48	2	664 735 106		SCHRAUBE		SCREW	VIS	TORNILLO
1	51	2	664 047 012		BUCHSE		BUSH	DOUILLE	CASQUILLO
1	52	2	664 430 577		FEDER		SPRING	RESSORT	MUELLE
1	53	4	664 670 008		SCHEIBE		WASHER	RONDELLE	ARANDELA
1	54	2	664 999 955		SPRENGRING		SNAP RING	ANNEAU RESSORT	ANILLO DE SUJECIÓN

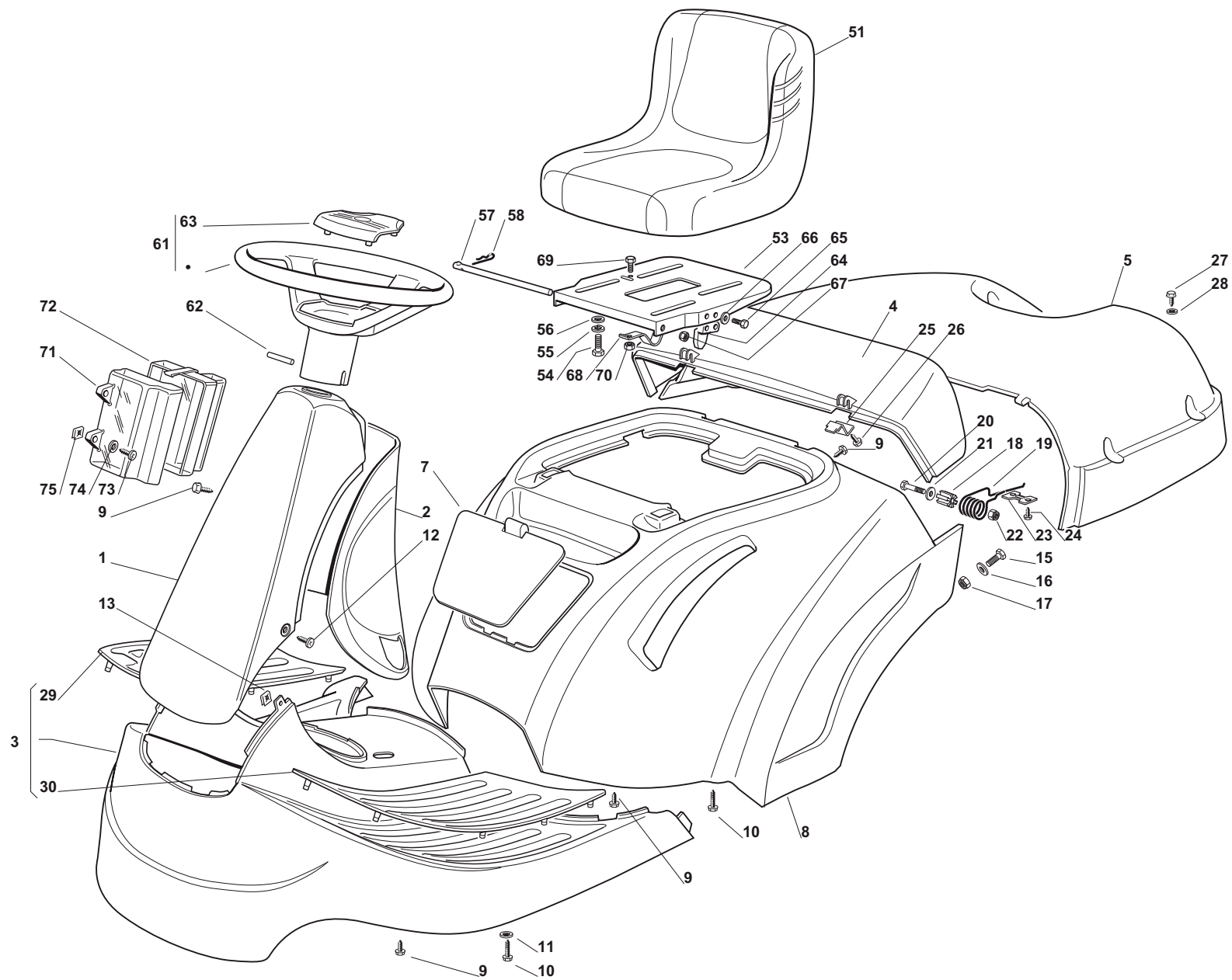

Seite / Page	Pos.	PRM0700 (2011)	Teil-Nr. Part No. No. de pièce No. de pieza	Hinweise Notes Renseign. Nota	Bezeichnung	Spezifikation Specification	Description	Désignation	Denominación
2	1	1	664 598 076		VORDERDECKEL ROT		FRONT COVER	COUVERCLE AVANT	CUBIERTA DELANTERA
2	2	1	664 600 111		HINTERDECKEL ROT		REAR COVER	COUVERCLE ARRIER	CUBIERTA TRASERA
2	3	1	664 110 130		FUSSBRETTDECKEL ROT		FOOTBOARD COVER	COUVRE MARCHEPIED	CUBIERTA DEL APOYAPIE
2	4	1	664 110 353		HAUBE ROT		GRASS-CATCHER COVER	COUVRE-BAC	CUBIERTA
2	5	1	664 110 354		HAUBE ROT		GRASS-CATCHER COVER	COUVRE-BAC	CUBIERTA
2	7	1	664 109 515		DECKEL ROT		FRONT COVER	COUVERCLE AVANT	TAPA
2	8	1	664 110 129		RADABDECKUNG, ROT		COVER	COUVERCLE	CONSOLA
2	9	10	664 735 402		SCHRAUBE		SCREW	VIS	TORNILLO
2	10	8	664 735 410		SCHRAUBE		SCREW	VIS	TORNILLO
2	11	4	664 523 040		SCHEIBE		WASHER	RONDELLE	ARANDELA
2	12	2	664 727 790		SCHRAUBE		SCREW	VIS	TORNILLO
2	13	2	664 437 503		PLATTE		PLATE	PLAQUE	PLACA
2	15	2	664 791 201		SCHRAUBE		SCREW	VIS	TORNILLO
2	16	2	664 523 040		SCHEIBE		WASHER	RONDELLE	ARANDELA
2	17	2	664 154 510		MUTTER		NUT	ECROU	TUERCA
2	18	2	664 047 003		BUCHSE		BUSH	DOUILLE	CASQUILLO
2	19	2	664 430 551		FEDER		SPRING	RESSORT	MUELLE
2	20	2	664 691 200		SCHRAUBE		SCREW	VIS	TORNILLO
2	21	2	664 523 070		SCHEIBE		WASHER	RONDELLE	ARANDELA
2	22	2	664 155 000		MUTTER		NUT	ECROU	TUERCA
2	23	2	664 546 001		PLATTE		PLATE	PLAQUE	PLACA
2	24	4	664 735 402		SCHRAUBE		SCREW	VIS	TORNILLO
2	25	2	664 546 003		PLATTE		PLATE	PLAQUE	PLACA
2	26	2	664 735 402		SCHRAUBE		SCREW	VIS	TORNILLO
2	27	4	664 729 601		SCHRAUBE		SCREW	VIS	TORNILLO
2	28	4	664 521 331		SCHEIBE		WASHER	RONDELLE	ARANDELA
2	29	1	664 110 314		FUSSBRETTDECKEL RECHTS		RIGHT FOOTBOARD COVER	COUVRE MARCHEPIED DRO.	TAPA APOYAPIES DER.
2	30	1	664 110 315		FUSSBRETTDECKEL LINKS		LEFT FOOTBOARD COVER	COUVRE MARCHEPIED GAU.	CUBIERTA APOYAPIES IZ.
2	51	1	664 722 463		SITZ		SEAT	SIEGE	ASIENTO
2	53	1	664 547 033		PLATTE		PLATE	PLAQUE	PLACA
2	54	4	664 793 101		SCHRAUBE		SCREW	VIS	TORNILLO
2	55	4	664 583 500		FEDERRING		GROWER	GROWER	ARANDELA ELÁSTICA
2	56	4	664 523 060		SCHEIBE		WASHER	RONDELLE	ARANDELA
2	57	1	664 864 052		BOLZEN		PIN	PIVOT	PIVOTE
2	58	1	664 487 997		SPLINT		COTTER PIN	GOUPILLE	PASADOR
2	61	1	664 961 216		LENKRAD		STEERING WHEEL	VOLANT	VOLANTE
2	62	1	664 620 299		STIFT		PIN	GOUPILLE	PASADOR
2	63	1	664 580 501		ABDECKUNG		CAP	CAPOT	CAPERUZA
2	64	1	664 063 021		NOCKEN		CAM	CAME	LEVA
2	65	2	664 789 100		SCHRAUBE		SCREW	VIS	TORNILLO
2	66	2	664 523 020		SCHEIBE		WASHER	RONDELLE	ARANDELA
2	67	2	664 154 330		MUTTER		NUT	ECROU	TUERCA

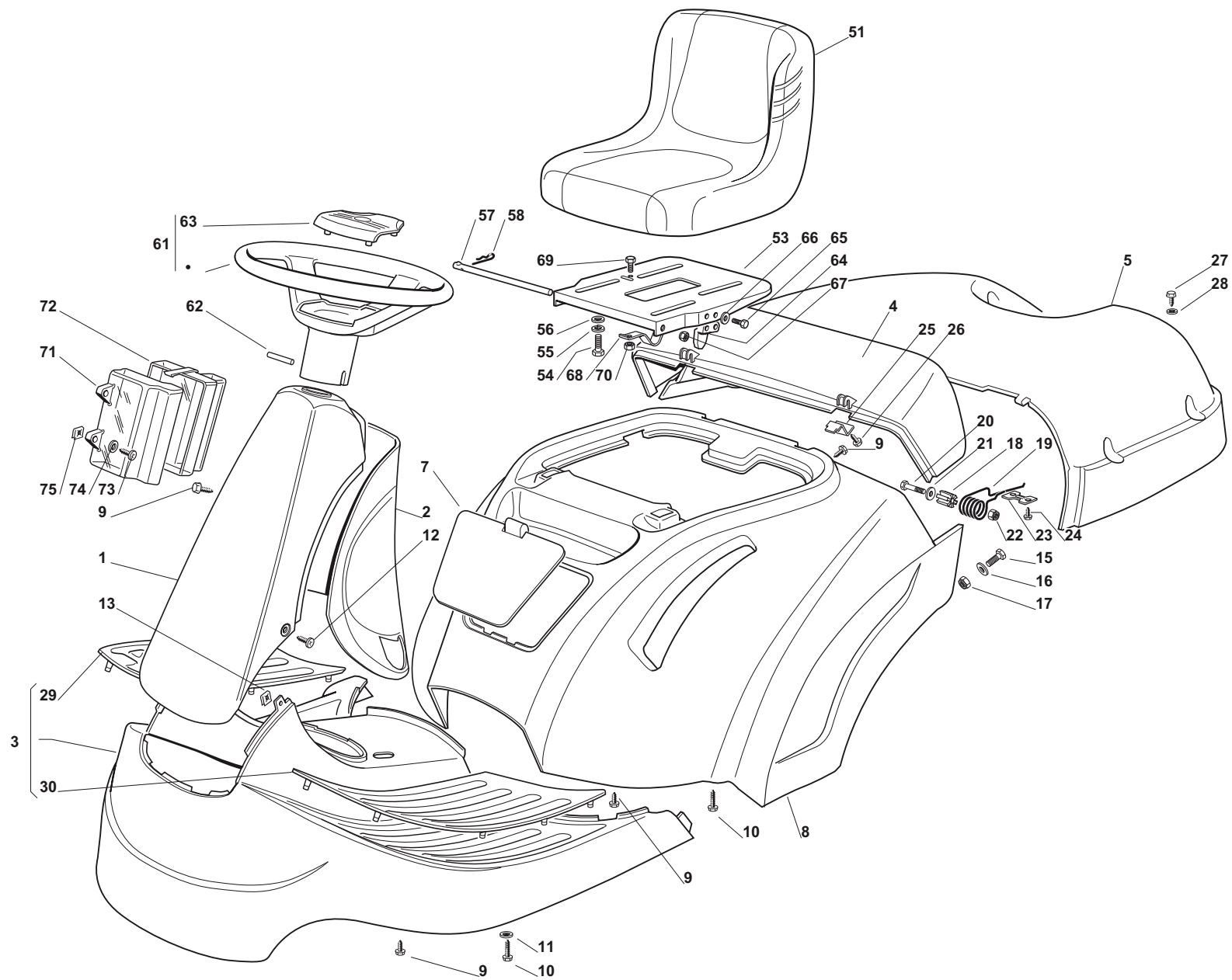

PRM0700 (2011)

2

KARROSSERIE  
 BODY  
 CARROSSERIE  
 CARROCERÍA



Seite / Page	Pos.	PRM0700 (2011)	Teil-Nr. Part No. No. de pièce No. de pieza	Hinweise Notes Renseign. Nota	Bezeichnung	Spezifikation Specification	Description	Désignation	Denominación
2	68	1	664 430 223		FEDER		SPRING	RESSORT	MUELLE
2	69	1	664 789 000		SCHRAUBE		SCREW	VIS	TORNILLO
2	70	1	664 154 330		MUTTER		NUT	ECROU	TUERCA
2	71	1	664 600 020		OBERSCHUTZ		UPPER GUARD	PROTECTION SUPERIEUR	PROTECCIÓN SUPERIOR
2	72	1	664 600 021		UNTERSCHUTZ		LOWER GUARD	PROTECTION INFERIEUR	PROTECCIÓN INFERIOR
2	73	2	664 728 460		SCHRAUBE		SCREW	VIS	TORNILLO
2	74	2	664 521 320		SCHEIBE		WASHER	RONDELLE	ARANDELA
2	75	2	664 437 502		PLATTE		PLATE	PLAQUE	PLACA

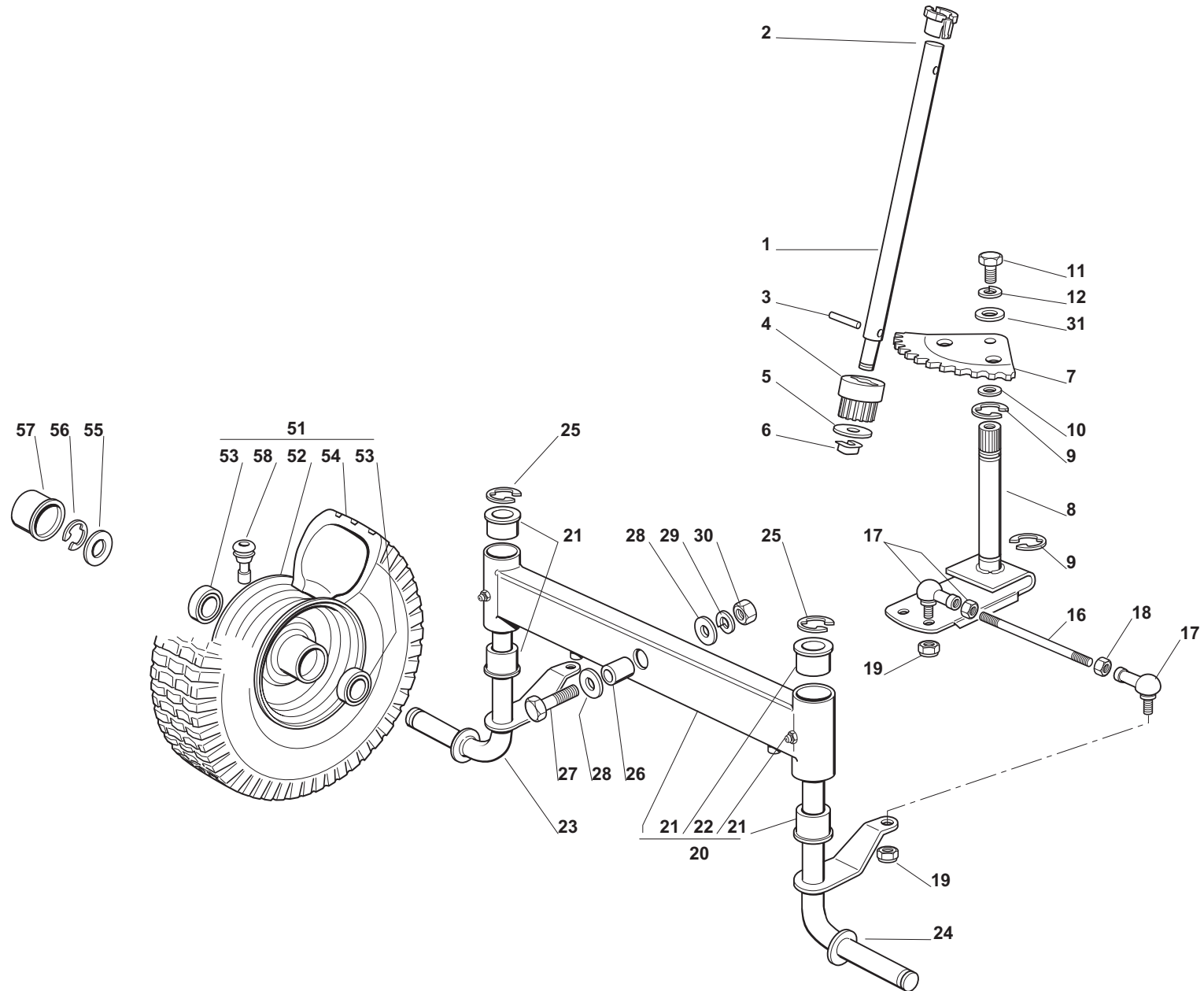



Seite / Page	Pos.	Teil-Nr. Part No. No. de pièce No. de pieza	Hinweise Notes Renseign. Nota	Bezeichnung	Spezifikation Specification	Description	Désignation	Denominación
3	1	664 520 050		LENKSÄULE		STEERING COLUMN	COLONNE DE DIRECTION	COLUMNA DE DIRECCIÓN
3	2	664 038 004		BUCHSE		BUSH	DOUILLE	CASQUILLO
3	3	664 622 650		STIFT		PIN	GOUPILLE	PASADOR
3	4	664 570 050		RITZEL		PINION	PIGNON	PIÑÓN
3	5	664 521 370		SCHEIBE		WASHER	RONDELLE	ARANDELA
3	6	664 436 030		PLÄTTCHEN		PLATE	PLAQUETTE	PLAQUITA
3	7	664 735 551		LENKWELLE		STEERING SHAFT	ARBRE DIRECTION	ÁRBOL DE DIRECCIÓN
3	8	664 999 501		WELLE		SHAFT	ARBRE	ÁRBOL
3	9	664 001 000		SPRENGRING		SNAP RING	ANNEAU RESSORT	ANILLO DE SUJECCIÓN
3	10	0-2 664 520 031		SCHEIBE		WASHER	RONDELLE	ARANDELA
3	11	664 793 102		SCHRAUBE		SCREW	VIS	TORNILLO
3	12	664 583 500		FEDERRING		GROWER	GROWER	ARANDELA ELÁSTICA
3	16	664 840 050		SPANNSTANGE		TIE ROD	TIRANT	SENSOR
3	17	664 746 609		GELENK		JOINT	JOINT	ARTICULACIÓN
3	18	664 295 201		MUTTER		NUT	ECROU	TUERCA
3	19	664 156 602		MUTTER		NUT	ECROU	TUERCA
3	20	664 034 057		KIPPEBEL		EQUALIZER	BALANCIER	PALANCA BASCULANTE
3	21	664 034 002		BUCHSE		BUSH	DOUILLE	CASQUILLO
3	22	664 379 511		FETTBUCHSE		GREASE DISPENSER	GRAISSEUR	CASQUILLO DE ENGRASE
3	23	664 230 401		ACHSSCHENKEL RECHTS		STUB AXLE RIGHT	FUSEAU DROITE	MANGUETA DERECHA
3	24	664 230 403		ACHSSCHENKEL LINKS		STUB AXLE LEFT	FUSEAU GAUCHE	MANGUETA IZQUIERDA
3	25	664 001 000		SPRENGRING		SNAP RING	ANNEAU RESSORT	ANILLO DE SUJECCIÓN
3	26	664 160 016		DISTANZRING		SPACER	ENTRETOISE	DISTANCIADOR
3	27	664 692 695		SCHRAUBE		SCREW	VIS	TORNILLO
3	28	664 523 100		SCHEIBE		WASHER	RONDELLE	ARANDELA
3	29	664 587 100		FEDERRING		GROWER	GROWER	ARANDELA ELÁSTICA
3	30	664 295 300		MUTTER		NUT	ECROU	TUERCA
3	31	664 521 350		SCHEIBE		WASHER	RONDELLE	ARANDELA
3	51	664 680 055		VORDERRAD		FRONT WHEEL	ROUE AVANT	RUEDA DELANTERA
3	52	664 044 000		FELGE		RIMM	JANTE	LLANTA
3	53	664 122 210		LAGER		BEARING	COUSSINET	RODAMIENTO
3	54	664 590 052		REIFEN		SHOE	PNEU	NEUMÁTICO
3	55	664 670 005		SCHEIBE		WASHER	RONDELLE	ARANDELA
3	56	664 001 000		SPRENGRING		SNAP RING	ANNEAU RESSORT	ANILLO DE SUJECCIÓN
3	57	664 110 230		NABENDECKEL		HUB COVER	COUVRE MOYEU	TAPACUBOS
3	58	664 950 000		VENTIL		VALVE	SOUPAPE	VÁLVULA

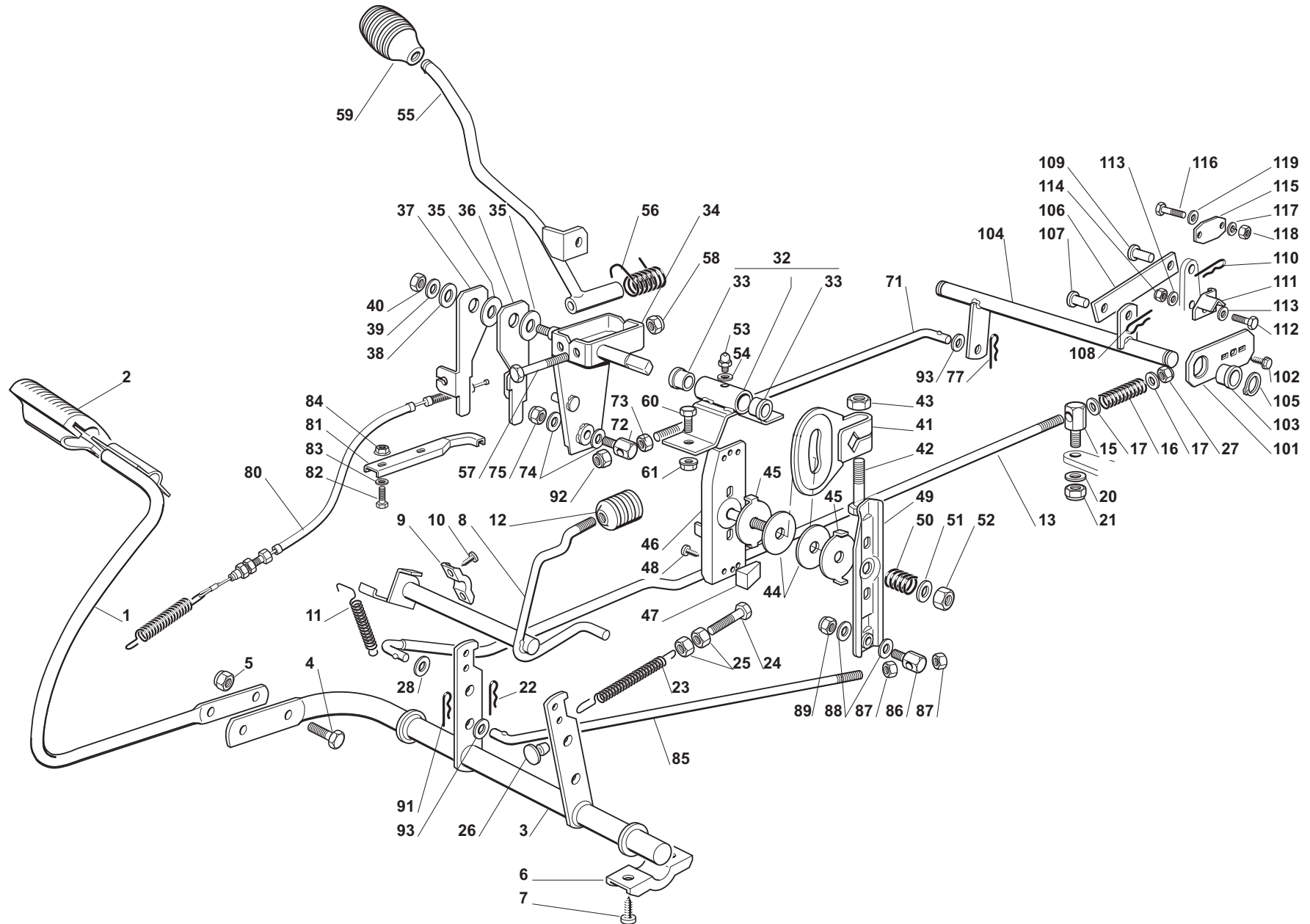

PRM0700 (2011)

4y

GETRIEBE UND BREMSE ANTRIEB  
DRIVE AND BRAKE CONTROLS  
COMMANDE TRANSMISSION ET FREIN  
ACCIONAMIENTO TRANSMISIÓN Y FRENOS



Seite / Page	Pos.	Teil-Nr. Part No. No. de pièce No. de pieza	Hinweise Notes Renseign. Nota	Bezeichnung	Spezifikation Specification	Description	Désignation	Denominación
4y	1	664 503 001		PEDAL		PEDAL	PEDAL	PEDAL
4y	2	664 110 267		PEDALGUMMI		CLAMP COVER	COUVRE ETRIER	GOMA DEL PEDAL
4y	3	664 001 015		ACHSE		AXLE	AXE	EJE
4y	4	664 793 301		SCHRAUBE		SCREW	VIS	TORNILLO
4y	5	664 155 000		MUTTER		NUT	ECROU	TUERCA
4y	6	664 546 015		PLATTE		PLATE	PLAQUE	PLACA
4y	7	664 731 350		SCHRAUBE		SCREW	VIS	TORNILLO
4y	8	664 001 011		ACHSE		AXLE	AXE	EJE
4y	9	664 547 049		PLATTE		PLATE	PLAQUE	PLACA
4y	10	664 731 601		SCHRAUBE		SCREW	VIS	TORNILLO
4y	11	664 430 552		FEDER		SPRING	RESSORT	MUELLE
4y	12	664 395 050		KNOPF		KNOB	POIGNEE	BOTÓN
4y	13	664 034 070		STANGE		ROD	BARRE	BARRA
4y	15	664 510 067		BOLZEN		PIN	PIVOT	PIVOTE
4y	16	664 430 236		FEDER		SPRING	RESSORT	MUELLE
4y	17	664 521 360		SCHEIBE		WASHER	RONDELLE	ARANDELA
4y	20	664 523 050		SCHEIBE		WASHER	RONDELLE	ARANDELA
4y	21	664 155 000		MUTTER		NUT	ECROU	TUERCA
4y	22	664 487 997		SPLINT		COTTER PIN	GOUPILLE	PASADOR
4y	23	664 430 210		FEDER		SPRING	RESSORT	MUELLE
4y	24	664 943 005		SCHRAUBE		SCREW	VIS	TORNILLO
4y	25	664 293 200		MUTTER		NUT	ECROU	TUERCA
4y	26	664 275 000		GUMMI		GROMMET	CAOUTCHOUC	CAUCHO
4y	27	664 156 602		MUTTER		NUT	ECROU	TUERCA
4y	28	664 670 011		SCHEIBE		WASHER	RONDELLE	ARANDELA
4y	32	664 773 568		LAGERBUCHSE		BRACKET WITH BUSH	INGSETRIER AVEC DOUILLES	CASQUILLO DEL RODAMIENTO
4y	33	664 045 080		LAGER		BEARING	COUSSINET	RODAMIENTO
4y	34	664 773 561		HEBEL		LEVER	LEVIER	PALANCA
4y	35	664 672 151		SCHEIBE		WASHER	RONDELLE	ARANDELA
4y	36	664 772 101		HEBEL LINKS		LEVER LEFT	LEVIER GAUCHE	PALANCA IZQUIERDA
4y	37	664 772 103		HEBEL RECHTS		LEVER RIGHT	LEVIER DROITE	PALANCA DERECHA
4y	38	664 672 152		SCHEIBE		WASHER	RONDELLE	ARANDELA
4y	39	664 523 060		SCHEIBE		WASHER	RONDELLE	ARANDELA
4y	40	664 155 010		MUTTER		NUT	ECROU	TUERCA
4y	41	664 734 055		SEKTOR		SECTOR	SECTEUR	SECTOR
4y	42	664 794 900		SCHRAUBE		SCREW	VIS	TORNILLO
4y	43	664 155 020		MUTTER		NUT	ECROU	TUERCA
4y	44	664 158 000		SCHEIBE		WASHER	RONDELLE	ARANDELA
4y	45	664 670 053		SCHEIBE		WASHER	RONDELLE	ARANDELA
4y	46	664 773 565		ZUGPLATTE		CLAMP	ETRIER	PLACA DE TRACCIÓN
4y	47	664 063 020		NOCKEN		CAM	CAME	LEVA
4y	48	664 735 110		SCHRAUBE		SCREW	VIS	TORNILLO

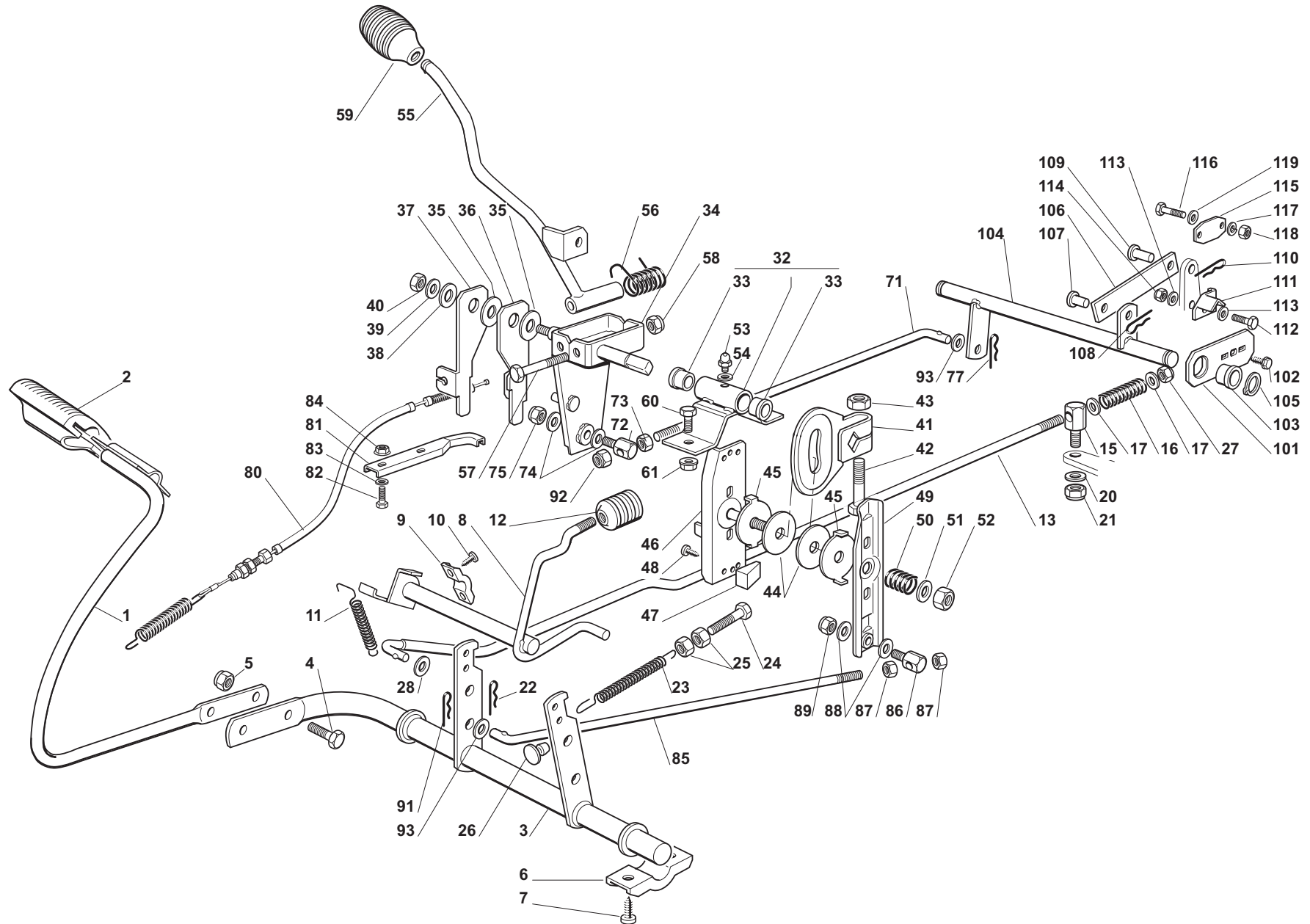

PRM0700 (2011)

4y

GETRIEBE UND BREMSE ANTRIEB  
DRIVE AND BRAKE CONTROLS  
COMMANDE TRANSMISSION ET FREIN  
ACCIONAMIENTO TRANSMISIÓN Y FRENOS



Seite / Page	Pos.	Teil-Nr. Part No. No. de pièce No. de pieza	Hinweise Notes Renseign. Nota	Bezeichnung	Spezifikation Specification	Description	Désignation	Denominación
4y	49	1 664 773 563		HEBEL		LEVER	LEVIER	PALANCA
4y	50	1 664 430 560		FEDER		SPRING	RESSORT	MUELLE
4y	51	1 664 670 008		SCHEIBE		WASHER	RONDELLE	ARANDELA
4y	52	1 664 155 020		MUTTER		NUT	ECROU	TUERCA
4y	53	1 664 379 511		FETTBUCHSE		GREASE DISPENSER	GRAISSEUR	CASQUILLO DE ENGRASE
4y	54	1 664 521 330		SCHEIBE		WASHER	RONDELLE	ARANDELA
4y	55	1 664 317 051		HEBEL		LEVER	LEVIER	PALANCA
4y	56	1 664 430 226		FEDER		SPRING	RESSORT	MUELLE
4y	57	1 664 692 050		SCHRAUBE		SCREW	VIS	TORNILLO
4y	58	1 664 155 000		MUTTER		NUT	ECROU	TUERCA
4y	59	1 664 394 508		KNAUF		KNOB	POIGNEE	MANETA
4y	60	2 664 793 102		SCHRAUBE		SCREW	VIS	TORNILLO
4y	61	2 664 293 201		MUTTER		NUT	ECROU	TUERCA
4y	71	1 664 034 071		STANGE		ROD	BARRE	BARRA
4y	72	1 664 510 040		BOLZEN		PIN	PIVOT	PIVOTE
4y	73	1 664 293 200		MUTTER		NUT	ECROU	TUERCA
4y	74	2 664 670 011		SCHEIBE		WASHER	RONDELLE	ARANDELA
4y	75	1 664 155 010		MUTTER		NUT	ECROU	TUERCA
4y	77	1 664 487 997		SPLINT		COTTER PIN	GOUPILLE	PASADOR
4y	80	1 664 207 101		BOWDENZUG		BOWDEN CABLE	CÂBLE BOWDEN	CABLE BOWDEN
4y	81	1 664 772 105		FÜHRUNG		CLAMP	ETRIER	GUÍA
4y	82	2 664 791 400		SCHRAUBE		SCREW	VIS	TORNILLO
4y	83	2 664 521 330		SCHEIBE		WASHER	RONDELLE	ARANDELA
4y	84	2 664 292 102		MUTTER		NUT	ECROU	TUERCA
4y	85	1 664 034 074		STANGE		ROD	BARRE	BARRA
4y	86	1 664 510 040		BOLZEN		PIN	PIVOT	PIVOTE
4y	87	2 664 293 200		MUTTER		NUT	ECROU	TUERCA
4y	88	2 664 670 011		SCHEIBE		WASHER	RONDELLE	ARANDELA
4y	89	1 664 155 010		MUTTER		NUT	ECROU	TUERCA
4y	91	1 664 487 997		SPLINT		COTTER PIN	GOUPILLE	PASADOR
4y	92	1 664 155 000		MUTTER		NUT	ECROU	TUERCA
4y	93	2 664 670 011		SCHEIBE		WASHER	RONDELLE	ARANDELA
4y	101	2 664 546 047		PLATTE		PLATE	PLAQUE	PLACA
4y	102	2 664 735 121		SCHRAUBE		SCREW	VIS	TORNILLO
4y	103	2 664 040 614		LAGER		BEARING	COUSSINET	RODAMIENTO
4y	104	1 664 001 023		ACHSE		AXLE	AXE	EJE
4y	105	2 664 608 900		SICHERUNGSRING		RETAINING RING	ANNEAU DE SÛRETÉ	ANILLO DE SEGURIDAD
4y	106	1 664 034 073		STANGE		ROD	BARRE	BARRA
4y	107	1 664 510 111		BOLZEN		PIN	PIVOT	PIVOTE
4y	108	1 664 487 997		SPLINT		COTTER PIN	GOUPILLE	PASADOR
4y	109	1 664 510 110		BOLZEN		PIN	PIVOT	PIVOTE
4y	110	1 664 487 997		SPLINT		COTTER PIN	GOUPILLE	PASADOR

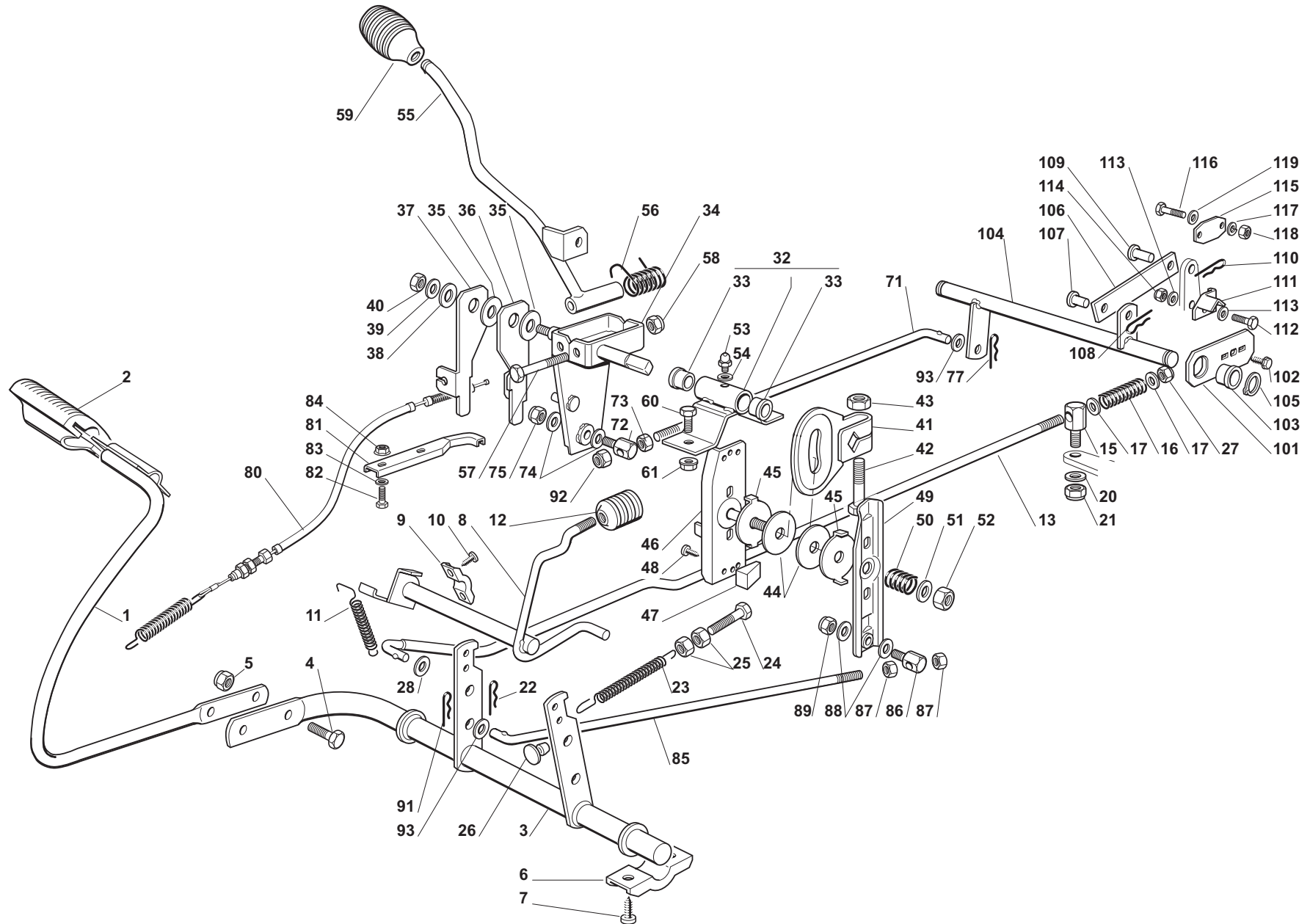

PRM0700 (2011)

4y

GETRIEBE UND BREMSE ANTRIEB  
 DRIVE AND BRAKE CONTROLS  
 COMMANDE TRANSMISSION ET FREIN  
 ACCIONAMIENTO TRANSMISIÓN Y FRENOS



Seite / Page	Pos.	PRM0700 (2011)	Teil-Nr. Part No. No. de pièce No. de pieza	Hinweise Notes Renseign. Nota	Bezeichnung	Spezifikation Specification	Description	Désignation	Denominación
4y	111	1	664 063 022		NOCKEN		CAM	CAME	LEVA
4y	112	1	664 791 400		SCHRAUBE		SCREW	VIS	TORNILLO
4y	113	2	664 521 330		SCHEIBE		WASHER	RONDELLE	ARANDELA
4y	114	1	664 154 510		MUTTER		NUT	ECROU	TUERCA
4y	115	1	664 546 019		PLATTE		PLATE	PLAQUE	PLACA
4y	116	2	664 735 602		SCHRAUBE		SCREW	VIS	TORNILLO
4y	117	2	664 581 100		FEDERRING		SPRING RING	BAGUE À RESSORT	ARANDELA ELÁSTICA
4y	118	2	664 290 791		MUTTER		NUT	ECROU	TUERCA
4y	119	2	664 540 020		SCHEIBE		WASHER	RONDELLE	ARANDELA



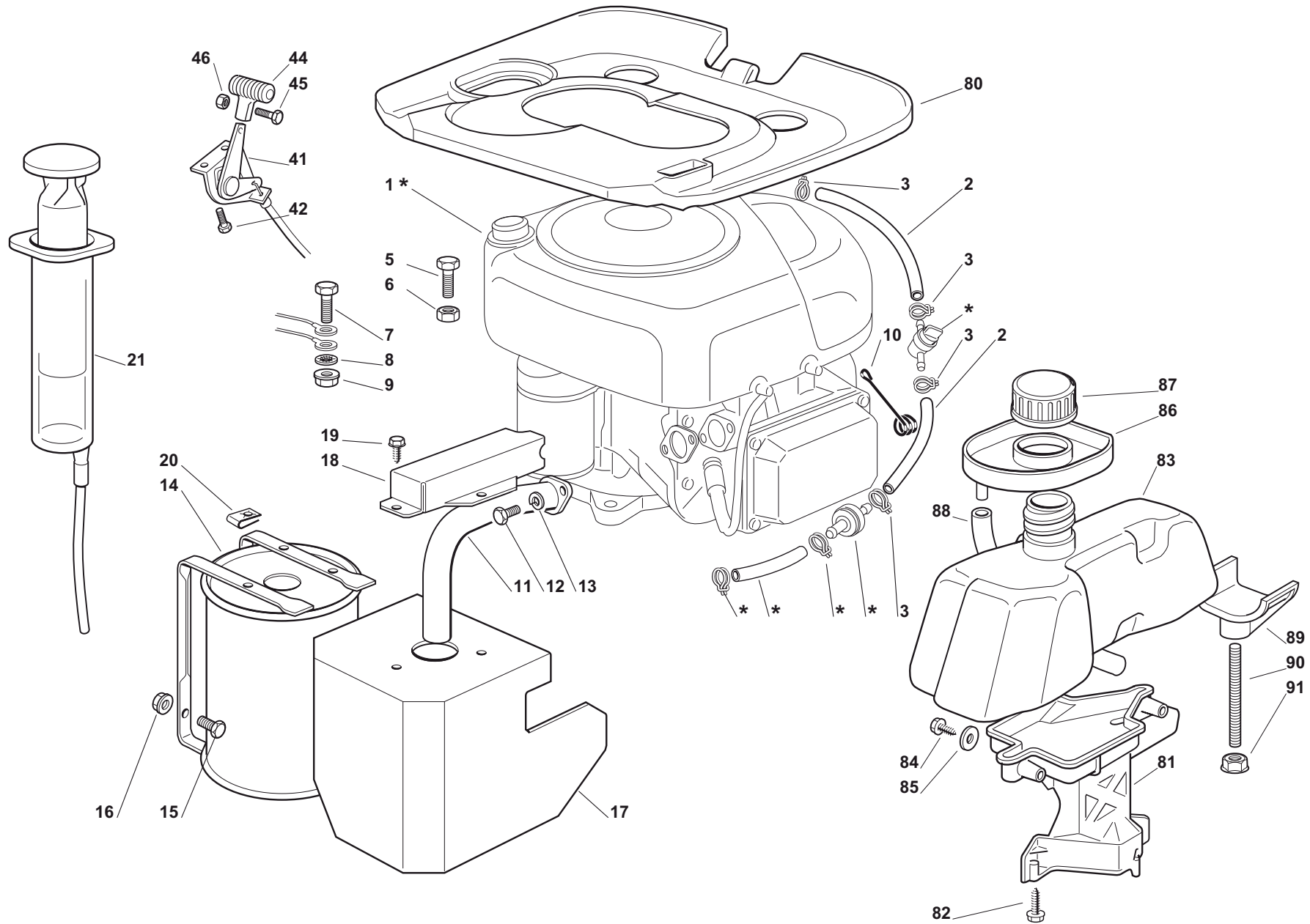



Seite / Page	Pos.	PRM0700 (2011)	Teil-Nr. Part No. No. de pièce No. de pieza	Hinweise Notes Renseign. Nota	Bezeichnung	Spezifikation Specification	Description	Désignation	Denominación
5	*	x			ZUM AUSTAUSCH DER MIT «*» GEKENNZEICHNETEN TEILE, WENDEN SIE SICH AN DEN KUNDENDIENST DES MOTORHERSTELLERS.		TO REPLACE THE PARTS MARKED «*» SEEK ASSISTANCE FROM THE ENGINE MANUFACTURER'S AFTER SALES SERVICE.	POUR LE REMPLACEMENT DES PIÈCES MARQUÉES AVEC «*» S'ADRESSER AU SERVICE APRÈS VENTES DU CONSTRUCTEUR DU MOTEUR.	PARA RECAMBIO DE LAS PIEZAS MARCADO CON «*» FAVOR SE DIRIGEN AL SERVICIO TÉCNICO DEL FABRICANTE DEL MOTOR.
5	1*	1			MOTOR	Tecumseh	MOTOR	MOTEUR	MOTOR
5	2	2	664 869 035		SCHLAUCH		TUBE	TUBE	TUBO
5	3	4	664 869 035		SCHLAUCH		TUBE	TUBE	TUBO
5	5	3	664 691 100		SCHRAUBE		SCREW	VIS	TORNILLO
5	6	3	664 154 210		MUTTER		NUT	ECROU	TUERCA
5	7	1	664 691 115		SCHRAUBE		SCREW	VIS	TORNILLO
5	8	1	664 540 260		SCHEIBE		WASHER	RONDELLE	ARANDELA
5	9	1	664 154 210		MUTTER		NUT	ECROU	TUERCA
5	10	1	664 430 239		FEDER		SPRING	RESSORT	MUELLE
5	11	1	664 738 225		AUSPUFFANSCHLUSS		EXHAUST CONNECTION	CONNEXION ECHAPPEMENT	CONEXIÓN DEL ESCAPE
5	12	2	664 737 450		SCHRAUBE		SCREW	VIS	TORNILLO
5	13	2	664 583 500		FEDERRING		GROWER	GROWER	ARANDELA ELÁSTICA
5	14	1	664 750 006		AUSPUFF		MUFFLER	SILENCIEUX	SILENCIADOR
5	15	2	664 793 102		SCHRAUBE		SCREW	VIS	TORNILLO
5	16	2	664 154 210		MUTTER		NUT	ECROU	TUERCA
5	17	1	664 598 081		AUSPUFFSCHUTZ		GUARD	PROTECTION	PROTECCIÓN
5	18	1	664 600 137		SCHUTZ		PROTECTION	PROTECTION	PROTECCIÓN
5	19	3	664 729 601		SCHRAUBE		SCREW	VIS	TORNILLO
5	20	3	664 437 504		PLATTE		PLATE	PLAQUE	PLACA
5	21	1	664 718 000		SPRITZE		SYRINGE	SIRINGUE	JERINGUILLA
5	41	1	664 999 250		GASZUG		BOWDEN CABLE	CÂBLE BOWDEN	TRACCIÓN BOWDEN
5	42	2	664 943 012		SCHRAUBE		SCREW	VIS	TORNILLO
5	44	1	664 394 501		GRIFF		HANDLE	POIGNEE	MANETA
5	45	1	664 726 399		SCHRAUBE		SCREW	VIS	TORNILLO
5	46	1	664 290 800		MUTTER		NUT	ECROU	TUERCA
5	80	1	664 110 306		MOTORABDECKUNG		MOTOR COVER	COUVERCLE MOTEUR	CUBIERTA DEL MOTOR
5	81	1	664 787 062		HALTER		SUPPORT	SUPPORT	SOPORTE
5	82	3	664 735 410		SCHRAUBE		SCREW	VIS	TORNILLO
5	83	1	664 733 003		TANK		TANK	RESERVOIR	DEPÓSITO
5	84	2	664 735 410		SCHRAUBE		SCREW	VIS	TORNILLO
5	85	2	664 523 040		SCHEIBE		WASHER	RONDELLE	ARANDELA
5	86	1	664 600 061		SCHUTZ		PROTECTION	PROTECTION	PROTECCIÓN
5	87	1	664 795 000		TANKVERSCHLUSS		CAP	BOUCHON	TAPÓN DEL DEPÓSITO
5	88	1	664 999 014		ROHR		TUBE	TUYAU	TUBO
5	89	1	664 787 063		HALTER		SUPPORT	SUPPORT	SOPORTE
5	90	1	664 510 118		BOLZEN		PIN	PIVOT	PIVOTE
5	91	2	664 293 201		MUTTER		NUT	ECROU	TUERCA

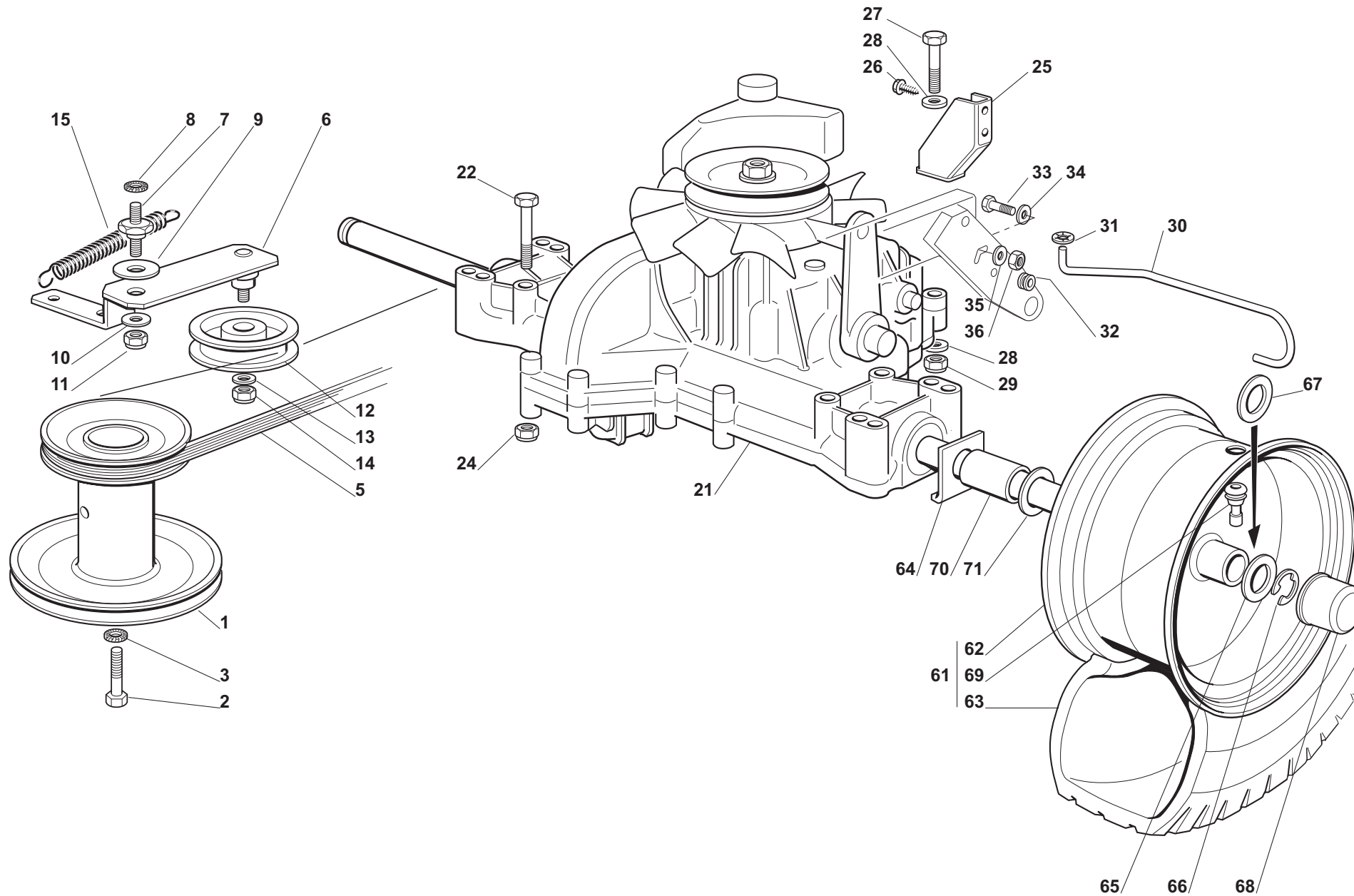

Seite / Page	Pos.	Teil-Nr. Part No. No. de pièce No. de pieza	Hinweise Notes Renseign. Nota	Bezeichnung	Spezifikation Specification	Description	Désignation	Denominación
6y	1	664 604 005		RIEMENSCHLEIBE		PULLEY	POULIE	POLEA
6y	2	664 737 310		SCHRAUBE		SCREW	VIS	TORNILLO
6y	3	664 543 000		SCHEIBE		WASHER	RONDELLE	ARANDELA
6y	5	664 061 404		RIEMEN		BELT	COURROIE	CORREA
6y	6	664 317 081		HEBEL		LEVER	LEVIER	PALANCA
6y	7	664 510 096		BOLZEN		PIN	PIVOT	PIVOTE
6y	8	664 540 260		SCHEIBE		WASHER	RONDELLE	ARANDELA
6y	9	664 672 151		SCHEIBE		WASHER	RONDELLE	ARANDELA
6y	10	664 670 011		SCHEIBE		WASHER	RONDELLE	ARANDELA
6y	11	664 155 010		MUTTER		NUT	ECROU	TUERCA
6y	12	664 601 554		RIEMENSCHLEIBE		PULLEY	POULIE	POLEA
6y	13	664 523 060		SCHEIBE		WASHER	RONDELLE	ARANDELA
6y	14	664 155 000		MUTTER		NUT	ECROU	TUERCA
6y	15	664 446 402		FEDER		SPRING	RESSORT	MUELLE
6y	21	664 400 965		HINTERACHSE		REAR AXLE	AXE ARRIERE	EJE TRASERO, ENGRANAJE CPL.
6y	22	664 691 800		SCHRAUBE		SCREW	VIS	TORNILLO
6y	24	664 154 210		MUTTER		NUT	ECROU	TUERCA
6y	25	664 783 019		HALTER		SUPPORT	SUPPORT	SOPORTE
6y	26	664 735 121		SCHRAUBE		SCREW	VIS	TORNILLO
6y	27	664 691 200		SCHRAUBE		SCREW	VIS	TORNILLO
6y	28	664 521 350		SCHEIBE		WASHER	RONDELLE	ARANDELA
6y	29	664 155 000		MUTTER		NUT	ECROU	TUERCA
6y	30	664 034 069		HEBEL		LEVER	LEVIER	PALANCA
6y	31	664 000 930		SPRENGRING		SAFETY WASHER	RONDELLE DE SÉCURITÉ	ANILLO DE SEGURIDAD
6y	32	664 564 512		KABELDURCHGANG		FAIR LEAD	PASSE CABLE	SUJETACABLE
6y	33	664 793 301		SCHRAUBE		SCREW	VIS	TORNILLO
6y	34	664 523 060		SCHEIBE		WASHER	RONDELLE	ARANDELA
6y	35	664 521 350		SCHEIBE		WASHER	RONDELLE	ARANDELA
6y	36	664 155 000		MUTTER		NUT	ECROU	TUERCA
6y	61	664 680 053		HINTERRAD		WHEEL	ROUE	RUEDA
6y	62	664 044 001		HINTERRAD FELGE		RIMM	BANDAGE ROUE	LLANTA RUEDA TRASERA
6y	63	664 590 053		REIFEN		SHOE	PNEU	NEUMÁTICO
6y	64	664 670 025		SCHEIBE		WASHER	RONDELLE	ARANDELA
6y	65	664 670 005		SCHEIBE		WASHER	RONDELLE	ARANDELA
6y	66	664 001 010		SPRENGRING		SNAP RING	ANNEAU RESSORT	ANILLO DE SUJECIÓN
6y	67	0-4 664 670 006		SCHEIBE		WASHER	RONDELLE	ARANDELA
6y	68	664 110 230		NABENDECKEL		HUB COVER	COUVRE MOYEU	TAPACUBOS
6y	69	664 950 000		VENTIL		VALVE	SOUPAPE	VÁLVULA
6y	70	664 160 031		DISTANZSTÜCK		SPACER	ENTRETOISE	SEPARADOR
6y	71	664 670 005		SCHEIBE		WASHER	RONDELLE	ARANDELA

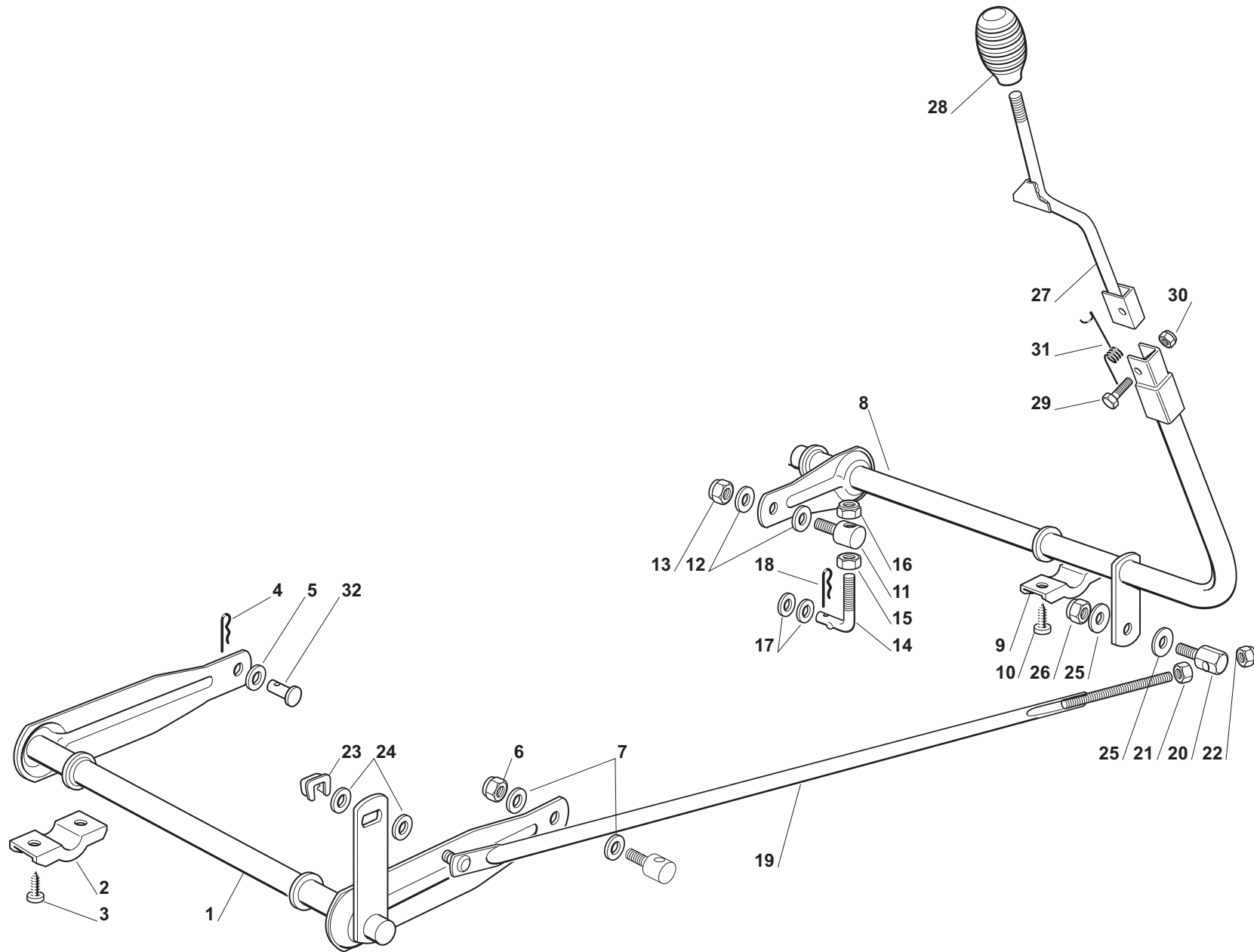

PRM0700 (2011)

7

SCHNEIDWERKZEUG AUFHEBESATZ  
CUTTING PLATE LIFTING  
SOULEVEMENT PLATEAU DE COUPE  
HERRAMIENTA DE CORTE PLATO DE ELEVACIÓN



Seite / Page	Pos.	Teil-Nr. Part No. No. de pièce No. de pieza	Hinweise Notes Renseignn. Nota	Bezeichnung	Spezifikation Specification	Description	Désignation	Denominación
7	1	1 664 001 025		ACHSE		AXLE	AXE	EJE
7	2	2 664 546 015		PLATTE		PLATE	PLAQUE	PLACA
7	3	4 664 731 350		SCHRAUBE		SCREW	VIS	TORNILLO
7	4	1 664 487 997		SPLINT		COTTER PIN	GOUPILLE	PASADOR
7	5	1 664 670 008		SCHEIBE		WASHER	RONDELLE	ARANDELA
7	6	1 664 156 602		MUTTER		NUT	ECROU	TUERCA
7	7	2 664 670 008		SCHEIBE		WASHER	RONDELLE	ARANDELA
7	8	1 664 001 005		ACHSE		AXLE	AXE	EJE
7	9	2 664 546 015		PLATTE		PLATE	PLAQUE	PLACA
7	10	4 664 731 350		SCHRAUBE		SCREW	VIS	TORNILLO
7	11	1 664 510 007		BOLZEN		PIN	PIVOT	PIVOTE
7	12	2 664 670 008		SCHEIBE		WASHER	RONDELLE	ARANDELA
7	13	1 664 156 602		MUTTER		NUT	ECROU	TUERCA
7	14	1 664 840 003		SPANNSTANGE		TIE ROD	TIRANT	SENSOR
7	15	1 664 295 200		MUTTER		NUT	ECROU	TUERCA
7	16	1 664 156 602		MUTTER		NUT	ECROU	TUERCA
7	17	2 664 672 150		SCHEIBE		WASHER	RONDELLE	ARANDELA
7	18	1 664 487 997		SPLINT		COTTER PIN	GOUPILLE	PASADOR
7	19	1 664 002 051		STAB		ROD	TIGE	VARILLA
7	20	1 664 510 040		BOLZEN		PIN	PIVOT	PIVOTE
7	21	1 664 293 200		MUTTER		NUT	ECROU	TUERCA
7	22	1 664 155 000		MUTTER		NUT	ECROU	TUERCA
7	23	1 664 436 050		PLATTE		PLATE	PLAQUE	PLACA
7	24	2 664 670 011		SCHEIBE		WASHER	RONDELLE	ARANDELA
7	25	2 664 670 011		SCHEIBE		WASHER	RONDELLE	ARANDELA
7	26	1 664 155 000		MUTTER		NUT	ECROU	TUERCA
7	27	1 664 317 065		HEBEL		LEVER	LEVIER	PALANCA
7	28	1 664 394 510		GRIFF		KNOB	POIGNEE	MANETA
7	29	1 664 674 700		SCHRAUBE		SCREW	VIS	TORNILLO
7	30	1 664 154 510		MUTTER		NUT	ECROU	TUERCA
7	31	1 664 430 555		FEDER		SPRING	RESSORT	MUELLE
7	32	1 664 510 114		BOLZEN		PIN	PIVOT	PIVOTE

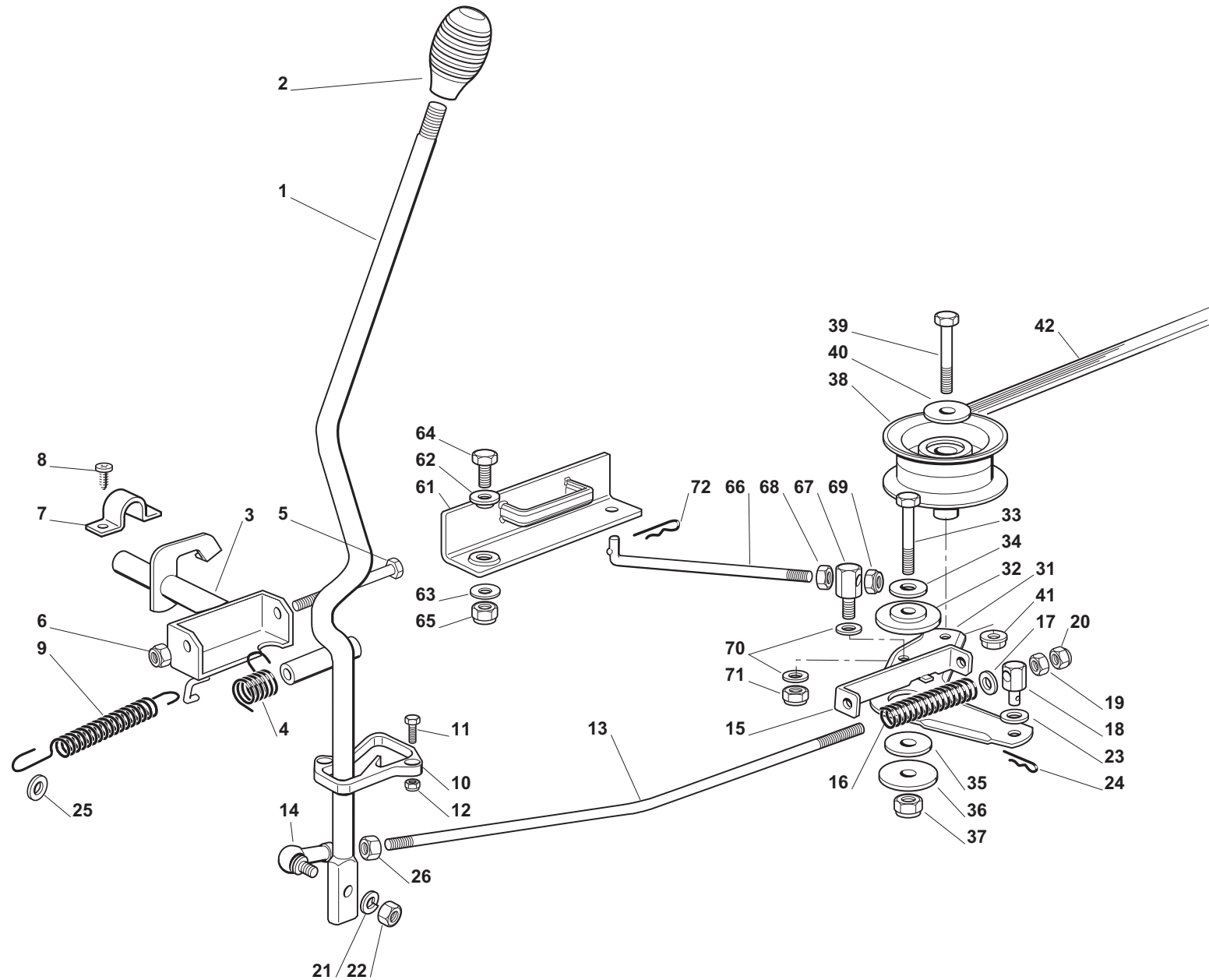

PRM0700 (2011)

8

SCHNEIDWERKZEUG (1)  
 CUTTING PLATE (1)  
 PLATEAU DE COUPE (1)  
 HERRAMIENTA DE CORTE (1)



Seite / Page	Pos.	Teil-Nr. Part No. No. de pièce No. de pieza	Hinweise Notes Renseign. Nota	Bezeichnung	Spezifikation Specification	Description	Désignation	Denominación
8	1	664 317 069		HEBEL		LEVER	LEVIER	PALANCA
8	2	664 394 510		GRIFF		KNOB	POIGNEE	MANETA
8	3	664 001 007		ACHSE		AXLE	AXE	EJE
8	4	664 430 226		FEDER		SPRING	RESSORT	MUELLE
8	5	664 692 050		SCHRAUBE		SCREW	VIS	TORNILLO
8	6	664 155 000		MUTTER		NUT	ECROU	TUERCA
8	7	664 547 049		PLATTE		PLATE	PLAQUE	PLACA
8	8	664 731 601		SCHRAUBE		SCREW	VIS	TORNILLO
8	9	664 430 571		FEDER		SPRING	RESSORT	MUELLE
8	10	664 487 000		GLEITBLOCK		SHOE	BLOC DE GLISSEMENT	BLOQUE DESLIZANTE
8	11	664 791 201		SCHRAUBE		SCREW	VIS	TORNILLO
8	12	664 154 510		MUTTER		NUT	ECROU	TUERCA
8	13	664 034 078		STAB		ROD	TIGE	VARILLA
8	14	664 746 610		GELENK		JOINT	JOINT	ARTICULACIÓN
8	15	664 772 143		KLAMMER FEDERDÄMPFER		CLAMP	ETRIER	GRAPA
8	16	664 430 576		FEDER		SPRING	RESSORT	MUELLE
8	17	664 521 350		SCHEIBE		WASHER	RONDELLE	ARANDELA
8	18	664 510 113		BOLZEN		PIN	PIVOT	PIVOTE
8	19	664 293 200		MUTTER		NUT	ECROU	TUERCA
8	20	664 155 000		MUTTER		NUT	ECROU	TUERCA
8	21	664 583 500		FEDERRING		GROWER	GROWER	ARANDELA ELÁSTICA
8	22	664 293 200		MUTTER		NUT	ECROU	TUERCA
8	23	664 670 008		SCHEIBE		WASHER	RONDELLE	ARANDELA
8	24	664 487 997		SPLINT		COTTER PIN	GOUPILLE	PASADOR
8	25	664 670 006		SCHEIBE		WASHER	RONDELLE	ARANDELA
8	26	664 293 200		MUTTER		NUT	ECROU	TUERCA
8	31	664 317 083		HEBEL		LEVER	LEVIER	PALANCA
8	32	664 047 000		BUCHSE		BUSH	DOUILLE	CASQUILLO
8	33	664 691 200		SCHRAUBE		SCREW	VIS	TORNILLO
8	34	664 523 060		SCHEIBE		WASHER	RONDELLE	ARANDELA
8	35	664 672 152		SCHEIBE		WASHER	RONDELLE	ARANDELA
8	36	664 523 070		SCHEIBE		WASHER	RONDELLE	ARANDELA
8	37	664 155 000		MUTTER		NUT	ECROU	TUERCA
8	38	664 604 008		RIEMENSCHLEIBE		PULLEY	POULIE	POLEA
8	39	664 691 600		SCHRAUBE		SCREW	VIS	TORNILLO
8	40	664 523 060		SCHEIBE		WASHER	RONDELLE	ARANDELA
8	41	664 293 200		MUTTER		NUT	ECROU	TUERCA
8	42	664 061 423		RIEMEN		BELT	COURROIE	CORREA
8	61	664 220 501		BREMSE		BRAKE	FREIN	FRENO
8	62	664 041 980		BUCHSE		BUSH	DOUILLE	CASQUILLO
8	63	664 672 152		SCHEIBE		WASHER	RONDELLE	ARANDELA
8	64	664 793 102		SCHRAUBE		SCREW	VIS	TORNILLO

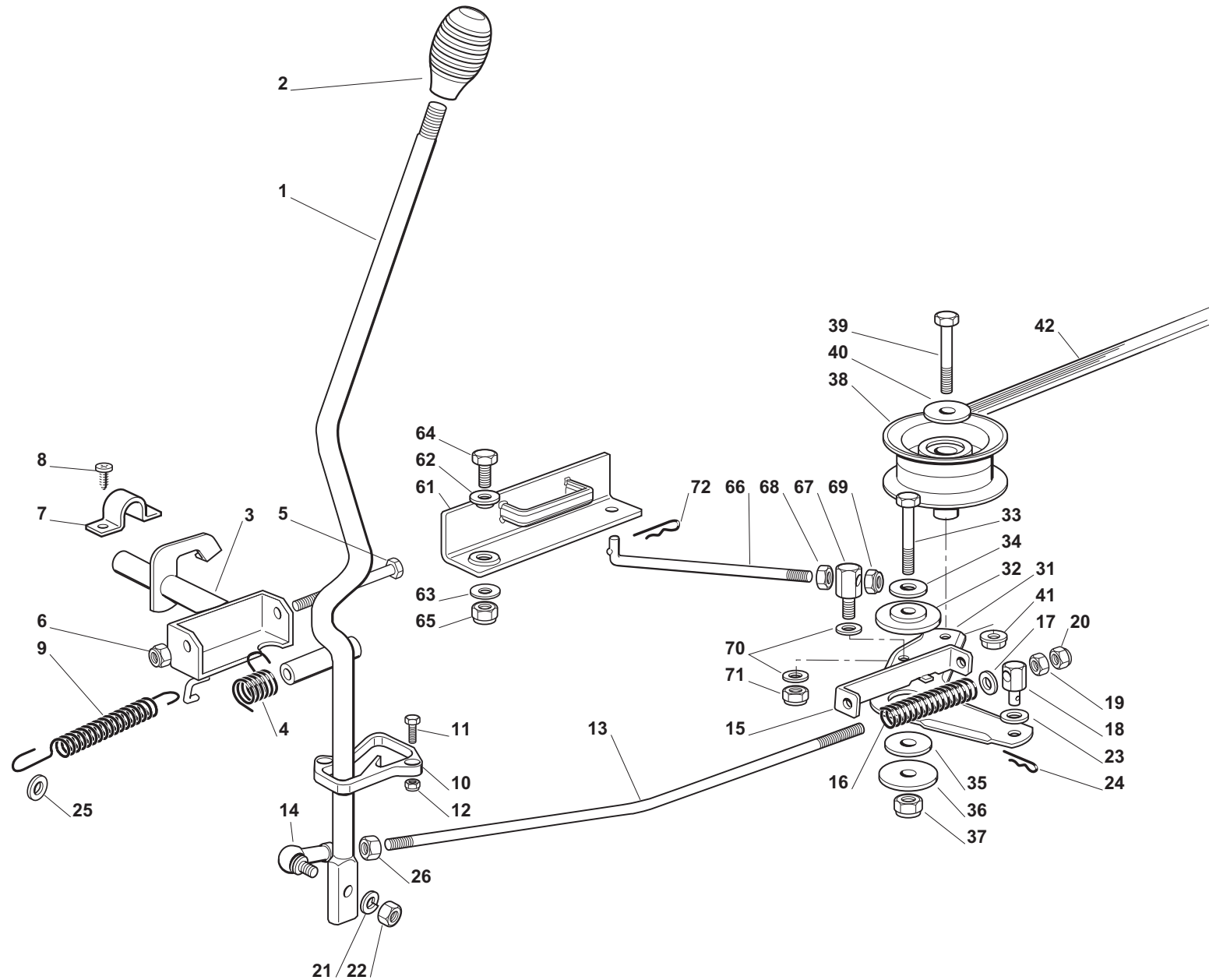



PRM0700 (2011)

8

SCHNEIDWERKZEUG (1)  
 CUTTING PLATE (1)  
 PLATEAU DE COUPE (1)  
 HERRAMIENTA DE CORTE (1)



Seite / Page	Pos.	PRM0700 (2011)	Teil-Nr. Part No. No. de pièce No. de pieza	Hinweise Notes Renseign. Nota	Bezeichnung	Spezifikation Specification	Description	Désignation	Denominación
8	65	1	664 155 010		MUTTER		NUT	ECROU	TUERCA
8	66	1	664 034 077		STAB		ROD	TIGE	VARILLA
8	67	1	664 510 040		BOLZEN		PIN	PIVOT	PIVOTE
8	68	1	664 293 200		MUTTER		NUT	ECROU	TUERCA
8	69	1	664 155 000		MUTTER		NUT	ECROU	TUERCA
8	70	2	664 670 011		SCHEIBE		WASHER	RONDELLE	ARANDELA
8	71	1	664 155 000		MUTTER		NUT	ECROU	TUERCA
8	72	1	664 487 997		SPLINT		COTTER PIN	GOUPILLE	PASADOR

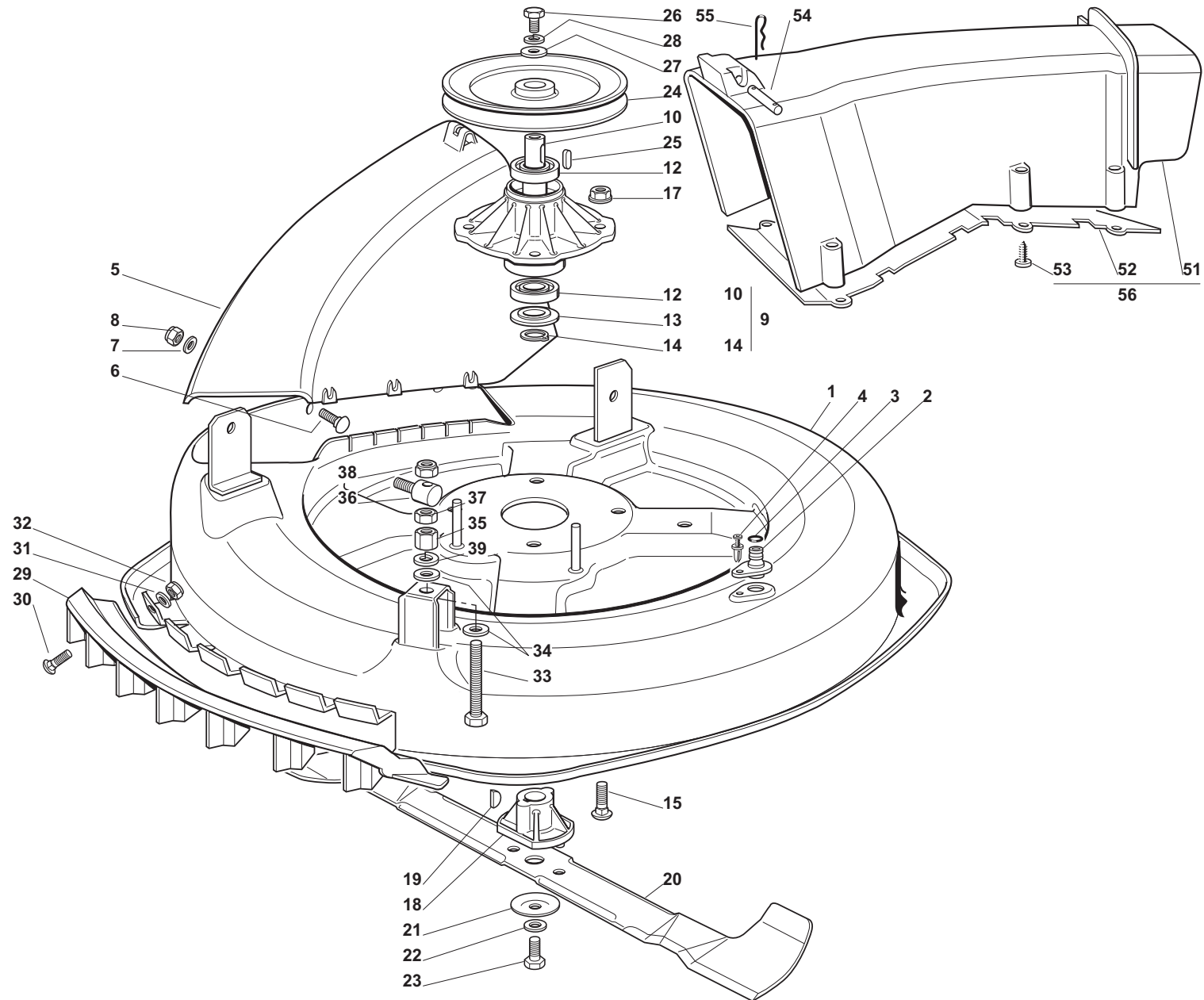

Seite / Page	Pos.	Teil-Nr. Part No. No. de pièce No. de pieza	Hinweise Notes Renseign. Nota	Bezeichnung	Spezifikation Specification	Description	Désignation	Denominación
9	1	1 664 640 751		MESSERTROMMEL		PLATE	PLATEAU	PLANCHA
9	2	1 664 033 060		WASSERANSCHLUSS		WATER HOSE CONNECTION	RACCORD TUYAU D'EAU	TOMA DE AGUA
9	3	1 664 035 000		O-RING		O-RING	O-RING	JUNTA TÓRICA
9	4	1 664 500 030		NIET		RIVET	RIVET	REMACHE
9	5	1 664 998 000		BLECHSATZ		CONVEYOR	CONVOYEUR	JUEGO DE CHAPA
9	6	6 664 815 210		SCHRAUBE		SCREW	VIS	TORNILLO
9	7	6 664 523 040		SCHEIBE		WASHER	RONDELLE	ARANDELA
9	8	6 664 154 510		MUTTER		NUT	ECROU	TUERCA
9	9	1 664 207 250		NABE, KPL.		FLANGE ASSY.	ENS. BRIDE	BRIDA CPL.
9	10	1 664 023 000		WELLE		SHAFT	ARBRE	ÁRBOL
9	12	2 664 216 047		KUGELLAGER		BALL BEARING	ROULEMENT À BILLES	RODAMIENTO DE BOLAS
9	13	1 664 160 501		STAUBSCHUTZSCHEIBE		DUST COVER	PROTEGE-POUSSIÈRE	CUBIERTA GUARDAPOLVO
9	14	1 664 609 260		SICHERUNGSRING		RETAINING RING	ANNEAU DE SÛRETÉ	ANILLO DE SEGURIDAD
9	15	4 664 818 700		SCHRAUBE		SCREW	VIS	TORNILLO
9	17	4 664 154 210		MUTTER		NUT	ECROU	TUERCA
9	18	1 664 463 200		MESSERHALTER		BLADE HUB	MOYEU LAME	SOPORTE DE LA CUCHILLA
9	19	1 664 139 100		KEIL		KEY	CLAVETTE	CHAVETA
9	20	1 664 109 502		FANGMESSER		BLADE (COLLECT)	LAME	CUCHILLA ESTÁNDAR
9	21	1 664 160 400		FEDERSCHEIBE		ELASTIC WASHER	RONDELLE ELASTIQUE	ARANDELA ELÁSTICA
9	22	1 664 523 080		SCHEIBE		WASHER	RONDELLE	ARANDELA
9	23	1 664 735 694		SCHRAUBE		SCREW	VIS	TORNILLO
9	24	1 664 604 009		RIEMENSCHLEIBE		PULLEY	POULIE	POLEA
9	25	1 664 139 480		KEIL		KEY	CLAVETTE	CHAVETA
9	26	1 664 793 102		SCHRAUBE		SCREW	VIS	TORNILLO
9	27	1 664 670 007		SCHEIBE		WASHER	RONDELLE	ARANDELA
9	28	1 664 583 500		FEDERRING		GROWER	GROWER	ARANDELA ELÁSTICA
9	29	1 664 488 000		ANSAUGGITTER		AIR INTAKE GRILL	GRILLE D'ASPIRATION	PARRILLA DE ASPIRACIÓN
9	30	4 664 815 200		SCHRAUBE		SCREW	VIS	TORNILLO
9	31	4 664 521 340		SCHEIBE		WASHER	RONDELLE	ARANDELA
9	32	4 664 154 510		MUTTER		NUT	ECROU	TUERCA
9	33	1 664 794 970		SCHRAUBE		SCREW	VIS	TORNILLO
9	34	2 664 523 080		SCHEIBE		WASHER	RONDELLE	ARANDELA
9	35	1 664 154 250		MUTTER		NUT	ECROU	TUERCA
9	36	1 664 510 007		BOLZEN		PIN	PIVOT	PIVOTE
9	37	1 664 295 200		MUTTER		NUT	ECROU	TUERCA
9	38	1 664 156 602		MUTTER		NUT	ECROU	TUERCA
9	39	1 664 585 100		FEDERRING		GROWER	GROWER	ARANDELA ELÁSTICA
9	51	1 664 107 501		BLECHSATZ		CONVEYOR	CONVOYEUR	JUEGO DE CHAPA
9	52	1 664 140 051		ABWEISER		DEFLECTOR	DEFLECTEUR	DEFLECTOR
9	53	8 664 735 402		SCHRAUBE		SCREW	VIS	TORNILLO
9	54	1 664 510 097		BOLZEN		PIN	PIVOT	PIVOTE
9	55	2 664 487 997		SPLINT		COTTER PIN	GOUILLE	PASADOR

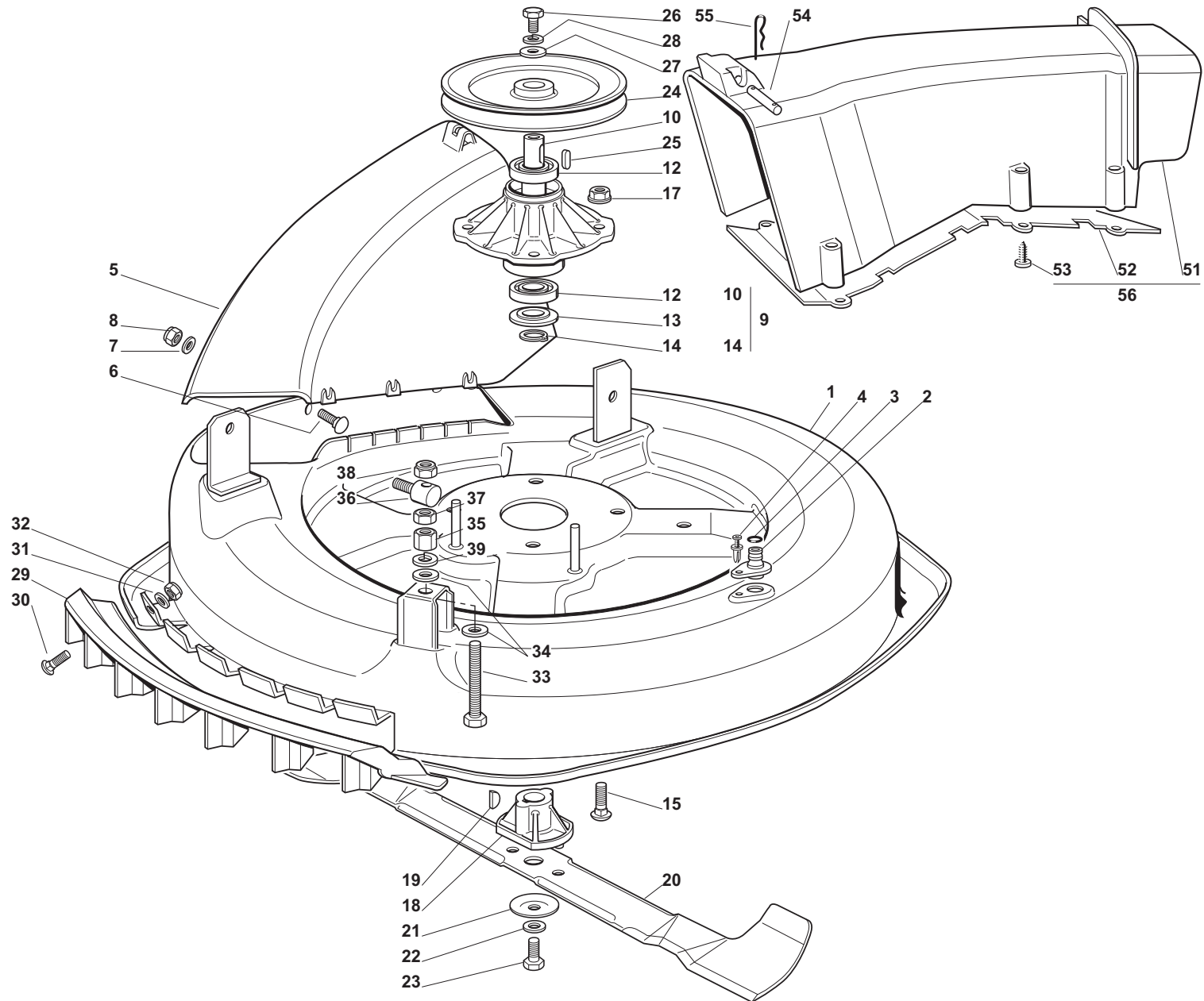

PRM0700 (2011)

9

SCHNEIDWERKZEUG (2)  
 CUTTING PLATE (2)  
 PLATEAU DE COUPE (2)  
 HERRAMIENTA DE CORTE (2)



Seite / Page	Pos.	PRM0700 (2011)	Teil-Nr. Part No. No. de pièce No. de pieza	Hinweise Notes Renseign. Nota	Bezeichnung	Spezifikation Specification	Description	Désignation	Denominación
9	56	1	664 108 051		BLECHSATZ KPL.		CONVEYOR ASSY.	ENS. CONVOYEUR	JUEGO DE CHAPA, CPL.

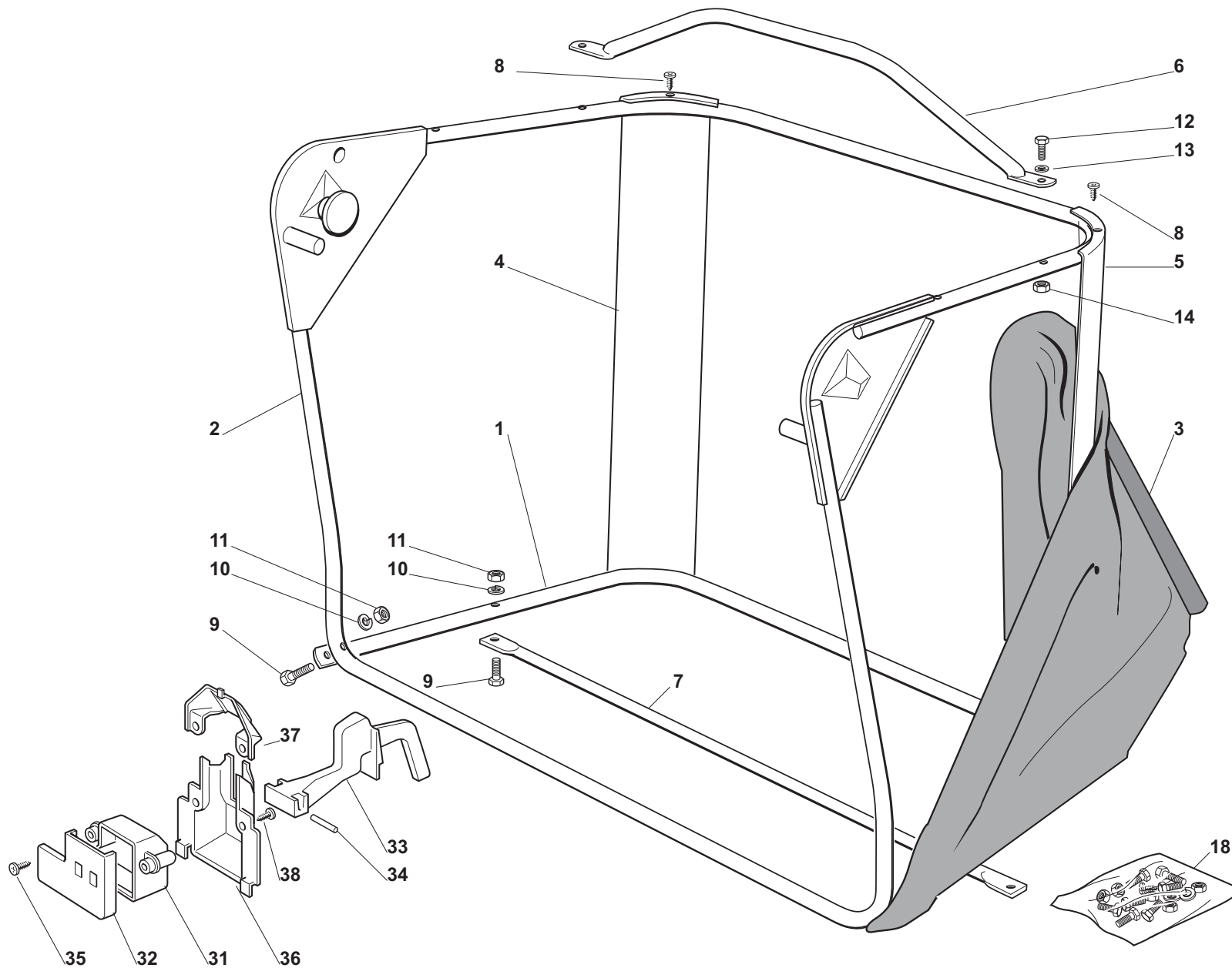

PRM0700 (2011)

10

GRASS-SACK  
GRASSCATCHER  
BAC  
CESTO

Seite / Page	Pos.	Teil-Nr. Part No. No. de pièce No. de pieza	Hinweise Notes Renseign. Nota	Bezeichnung	Spezifikation Specification	Description	Désignation	Denominación
10	1	664 801 103		UNTERERRAHMEN		LOWER FRAME	CHASSIS INFÉRIEUR	CHASIS INFERIOR
10	2	664 801 105		OBERERRAHMEN		UPPER FRAME	CHASSIS SUPÉRIEUR	CHASIS SUPERIOR
10	3	664 106 069		GRASS-SACK		GRASS CATCHER	BAC	CESTO
10	4	664 010 205		HALTER RECHTS		SUPPORT RIGHT	SUPPORT DROITE	SOPORTE DER.
10	5	664 010 207		HALTER LINKS		SUPPORT LEFT	SUPPORT GAUCHE	SOPORTE IZQ.
10	6	664 869 051		STANGE		ROD	BARRE	BARRA
10	7	664 650 100		VERSTÄRKUNG		STIFFENING	REINFORCEMENT	REFUERZO INFERIOR
10	8	664 729 601		SCHRAUBE		SCREW	VIS	TORNILLO
10	9	664 792 099		SCHRAUBE		SCREW	VIS	TORNILLO
10	10	664 582 101		FEDERRING		GROWER	GROWER	ARANDELA ELÁSTICA
10	11	664 292 100		MUTTER		NUT	ECROU	TUERCA
10	12	664 674 701		SCHRAUBE		SCREW	VIS	TORNILLO
10	13	664 521 331		SCHEIBE		WASHER	RONDELLE	ARANDELA
10	14	664 154 510		MUTTER		NUT	ECROU	TUERCA
10	18	664 180 180		SCHRAUBENAUSRÜSTUNG		SCREWS OUTFIT	ENSEMBLE DES VIS	JUEGO DE TORNILLOS
10	31	664 600 041		SCHUTZ		PROTECTION	PROTECTION	PROTECCIÓN
10	32	664 600 042		SCHUTZDECKEL		PROTECTION COVER	COUVERCLE PROTECTION	CUBIERTA PROTECTORA
10	33	664 318 124		HEBEL		LEVER	LEVIER	PALANCA
10	34	664 400 030		BOLZEN		PIN	PIVOT	PIVOTE
10	35	664 728 510		SCHRAUBE		SCREW	VIS	TORNILLO
10	36	664 600 047		SCHUTZ		PROTECTION	PROTECTION	PROTECCIÓN
10	37	664 600 048		ABWEISERDECKEL		DEFLECTOR COVER	COUVERCLE DEFLECTEUR	CUBIERTA DEL DEFLECTOR
10	38	664 728 450		SCHRAUBE		SCREW	VIS	TORNILLO

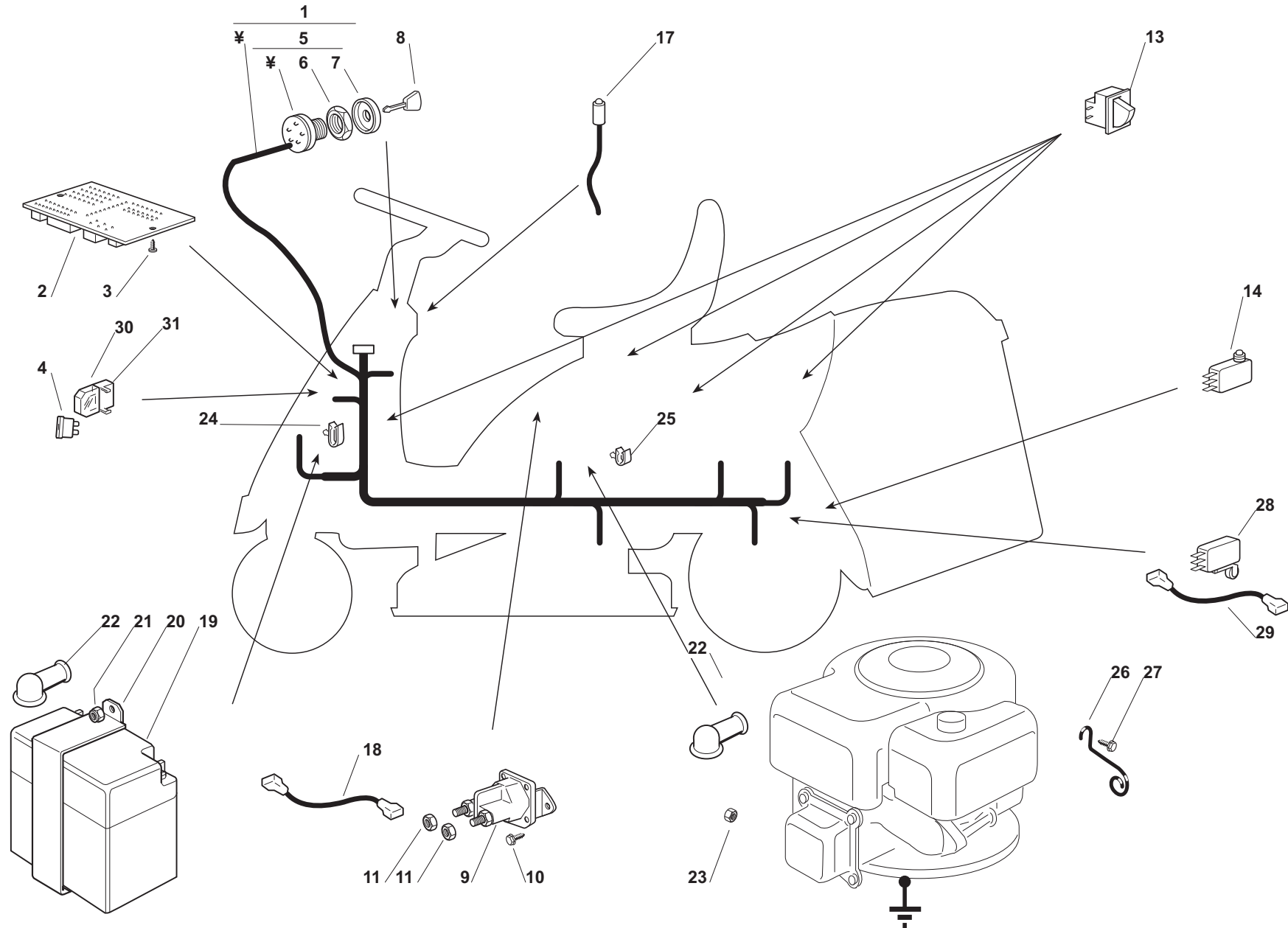



Seite / Page	Pos.	Teil-Nr. Part No. No. de pièce No. de pieza	Hinweise Notes Renseign. Nota	Bezeichnung	Spezifikation Specification	Description	Désignation	Denominación
11	1	664 997 126		KABELSATZ		SET OF WIRES	JEU DE CÂBLES	JUEGO DE CABLES
11	2	664 722 415		ELEKTRONISCHE KARTE		ELECTRONIC CARD	CARTE ELECTRONIQUE	TARJETA ELECTRÓNICA
11	3	664 727 810		SCHRAUBE		SCREW	VIS	TORNILLO
11	4	664 340 040		SICHERUNG		FUSE	FUSIBLE	FUSIBLE
11	4	664 340 036		SICHERUNG		FUSE	FUSIBLE	FUSIBLE
11	5	664 450 065		SCHALTER		STARTING SWITCH	INTERRUPTEUR DEMARRAGE	INTERRUPTOR DE ENCENDIDO
11	6	664 400 861		NUTMUTTER		RING NUT	EMBOUT	TUERCA RANURADA
11	7	664 565 351		NUTMUTTER SCHUTZ		SCREWED RING PROTECTION	PROTECTION EMBOUT	PROTECCIÓN TUERCA RANURADA
11	8	664 210 016		SCHLÜSSEL FÜR START		STARTING KEY	CLEF A DEMARRAGE	LLAVE DE ENCENDIDO
11	9	664 736 110		ANLASSRELAIS		STARTER RELAY	RELAIS D'ALLUMAGE	RELÉ DE ARRANQUE
11	10	664 735 110		SCHRAUBE		SCREW	VIS	TORNILLO
11	11	664 360 352		MUTTER		NUT	ECROU	TUERCA
11	13	664 410 615		MIKROSCHALTER		MICRO SWITCH	INTERRUPTEUR	INTERRUPTOR
11	14	664 410 605		FÜLLHÖHENSCHALTER		FULL GRASS CATCHER MICRO	MICRO BAC PLEIN	MICRO. CESTO LLENO
11	17	664 065 014		KABEL		CABLE	CÂBLE	CABLE
11	18	664 065 050		KABEL		CABLE	CÂBLE	CABLE
11	19	664 120 002		BATTERIE		BATTERY	BATTERIE	BATERÍA
11	20	664 772 099		BATTERIEHALTER		CLAMP	ETRIER	SOPORTE DE BATERÍA
11	21	664 155 000		MUTTER		NUT	ECROU	TUERCA
11	22	664 564 861		STECKER		PROTECTION	CAPUCHON	CAPUCHÓN
11	23	664 361 005		MUTTER		NUT	ECROU	TUERCA
11	24	664 320 506		KABELBEFESTIGUNG		FAIRLEAD	FIXATION CABLE	SUJETACABLE
11	25	664 320 504		KABELBEFESTIGUNG		FAIRLEAD	FIXATION CABLE	SUJETACABLE
11	26	664 430 561		FEDER		SPRING	RESSORT	MUELLE
11	27	664 735 121		SCHRAUBE		SCREW	VIS	TORNILLO
11	28	664 410 609		MIKROSCHALTER LEERLAUF		SWITCH	INTERRUPTEUR	INTERRUPTOR
11	29	664 065 025		KABEL		CABLE	CÂBLE	CABLE
11	30	664 215 000		DECKEL		COVER	COUVERCLE	CUBIERTA
11	31	664 500 007		SICHERUNGHALTER		FUSE CARRIER	TABLEAU DE FUSIBLE	SOPORTE

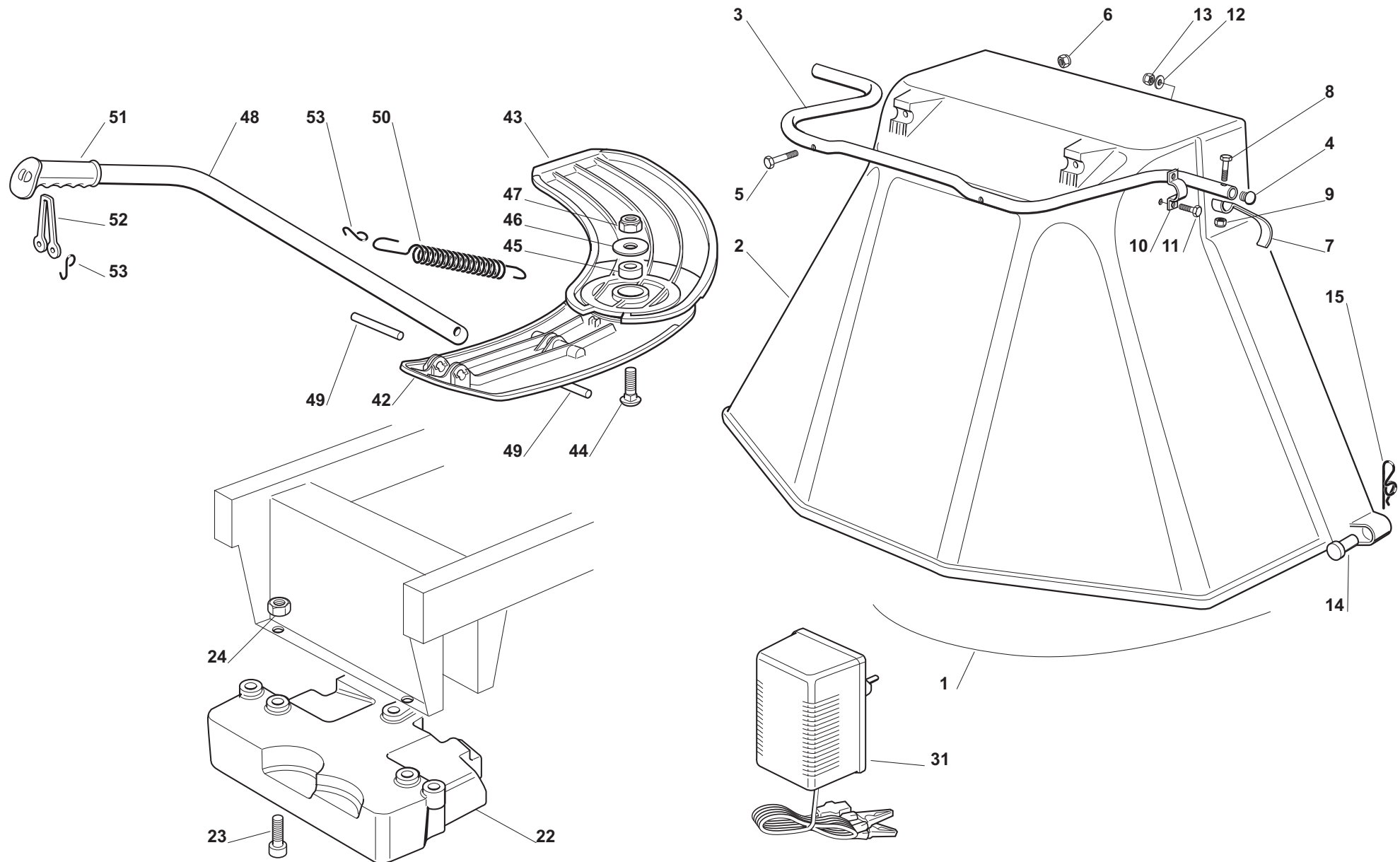

Seite / Page	Pos.	Teil-Nr. Part No. No. de pièce No. de pieza	Hinweise Notes Renseign. Nota	Bezeichnung	Spezifikation Specification	Description	Désignation	Denominación
12	2	1 664 598 062		AUSWURFSCHUTZ		EJECTION GUARD	PROTECTION SORTIE	PROTECCIÓN DE SALIDA
12	3	1 664 869 053		HALTER		SUPPORT	SUPPORT	SOPORTE
12	4	2 664 566 113		PFROPFEN		CAP	BOUCHON	TAPÓN
12	5	2 664 674 701		SCHRAUBE		SCREW	VIS	TORNILLO
12	6	2 664 154 510		MUTTER		NUT	ECROU	TUERCA
12	7	1 664 547 053		PLÄTTCHEN		PLATE	PLAQUETTE	PLAQUITA
12	8	1 664 791 500		SCHRAUBE		SCREW	VIS	TORNILLO
12	9	1 664 154 510		MUTTER		NUT	ECROU	TUERCA
12	10	2 664 547 049		PLATTE		PLATE	PLAQUE	PLACA
12	11	4 664 788 910		SCHRAUBE		SCREW	VIS	TORNILLO
12	12	4 664 523 020		SCHEIBE		WASHER	RONDELLE	ARANDELA
12	13	4 664 154 320		MUTTER		NUT	ECROU	TUERCA
12	14	2 664 510 022		BOLZEN		PIN	PIVOT	PIVOTE
12	15	2 664 487 997		SPLINT		COTTER PIN	GOUPILLE	PASADOR
12	22	1 664 519 997		GEWICHT		WEIGHT	POIDS	PESO
12	23	3 664 760 520		SCHRAUBE		SCREW	VIS	TORNILLO
12	24	3 664 155 000		MUTTER		NUT	ECROU	TUERCA
12	31	1 664 180 050		BATTERIELADEGERÄT	DE	BATTERY CHARGER	CHARGEUR DE BATTERIES	CARGADOR DE BATERÍAS
12	31	1 664 180 052		BATTERIELADEGERÄT	UK	BATTERY CHARGER	CHARGEUR DE BATTERIES	CARGADOR DE BATERÍAS
12	42	1 664 140 055		ABWEISER, HINTER		DEFLECTOR, REAR	DEFLECTEUR, ARRIERE	DEFLECTOR, DETRÁS
12	43	1 664 140 054		ABWEISER, VORDER		DEFLECTOR, FRONT	DEFLECTEUR, AVANT	DEFLECTOR, DELANTE
12	44	1 664 818 700		SCHRAUBE		SCREW	VIS	TORNILLO
12	45	1 664 047 013		LAGER		BEARING	COUSSINET	RODAMIENTO
12	46	1 664 672 152		SCHEIBE		WASHER	RONDELLE	ARANDELA
12	47	1 664 155 000		MUTTER		NUT	ECROU	TUERCA
12	48	1 664 394 003		STIEL		HANDLE	GUIDON	MANGO
12	49	2 664 510 116		BOLZEN		PIN	PIVOT	PIVOTE
12	50	1 664 430 229		FEDER		SPRING	RESSORT	MUELLE
12	51	1 664 280 000		GRIFF		HANDGRIP	BRANCHE	MANETA
12	52	1 664 840 011		GUMMIZUG		ELASTIC TIE-ROD	TIRANT ELASTIQUE	TENSOR DE GOMA
12	53	3 664 253 004		HAKEN		HOOK	CROCHET	GANCHO

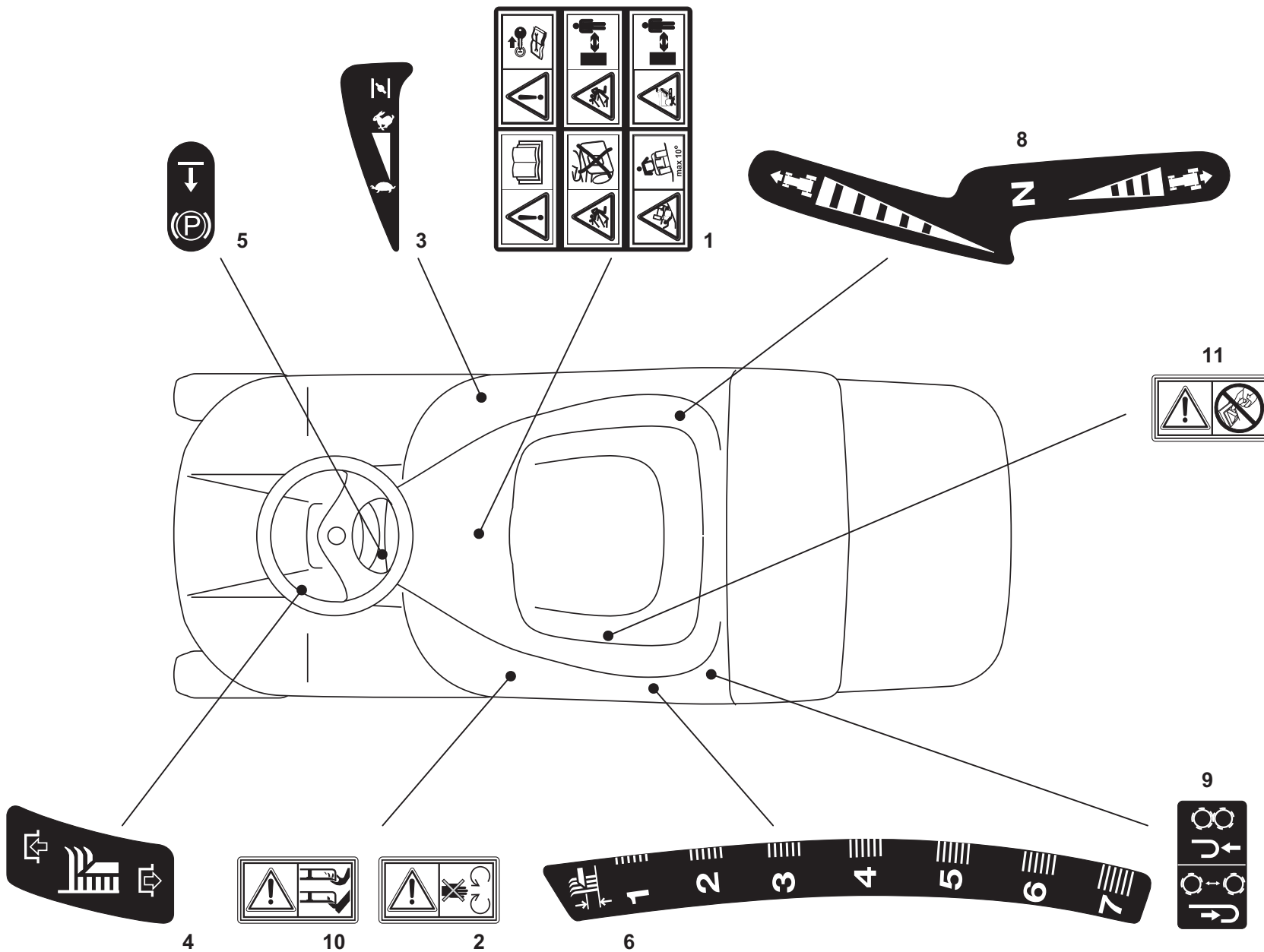

Seite / Page	Pos.	PRM0700 (2011)	Teil-Nr. Part No. No. de pièce No. de pieza	Hinweise Notes Renseign. Nota	Bezeichnung	Spezifikation Specification	Description	Désignation	Denominación
13	1	1	664 357 428		SCHILD SICHERHEITSHINWEISE		LABEL, SAFETY INSTRUCTIONS	ETIQUETTE, INSTRUCTIONS DE SÉCURITÉ	ETIQUETA, SEGURIDAD
13	2	1	664 998 519		SCHILD SICHERHEITSHINWEISE		LABEL, SAFETY INSTRUCTIONS	ETIQUETTE, INSTRUCTIONS DE SÉCURITÉ	ETIQUETA, SEGURIDAD
13	3	1	664 998 425		SCHILD, MOTORFERNBEDIENUNG		LABEL, THROTTLE	ETIQUETTE, ACCELERATEUR	ETIQUETA, ACELERADOR
13	4	1	664 357 431		SCHILD, MESSERKUPPLUNG		LABEL, KNIFE COUPLING	ETIQUETTE, ACCOUPLEMENT DE LAME	ETIQUETA, ACOPLAMIENTO DE LA CUCHILLA
13	5	1	664 998 526		SCHILD, PARKBREMSE		LABEL, PARKING BRAKE	ETIQUETTE	ETIQUETA
13	6	1	664 357 427		SCHILD, SCHNITTHÖHENVERSTELLUNG		LABEL, HEIGHT ADJUSTMENT	ETIQUETTE, REGLAGE HAUTEUR	ETIQUETA, AJUSTE ALTURA
13	8	1	664 357 702		SCHILD, VORSCHUB		LABEL, FEED RATE	ETIQUETTE, AVANCEMENT	ETIQUETA
13	9	1	664 358 513		SCHILD		LABEL	ETIQUETTE	ETIQUETA
13	10	2	664 356 699		SCHILD SICHERHEITSHINWEISE		LABEL, SAFETY INSTRUCTIONS	ETIQUETTE, INSTRUCTIONS DE SÉCURITÉ	ETIQUETA, SEGURIDAD
13	11	1	664 360 118		SCHILD SICHERHEITSHINWEISE		LABEL, SAFETY INSTRUCTIONS	ETIQUETTE, INSTRUCTIONS DE SÉCURITÉ	ETIQUETA, SEGURIDAD

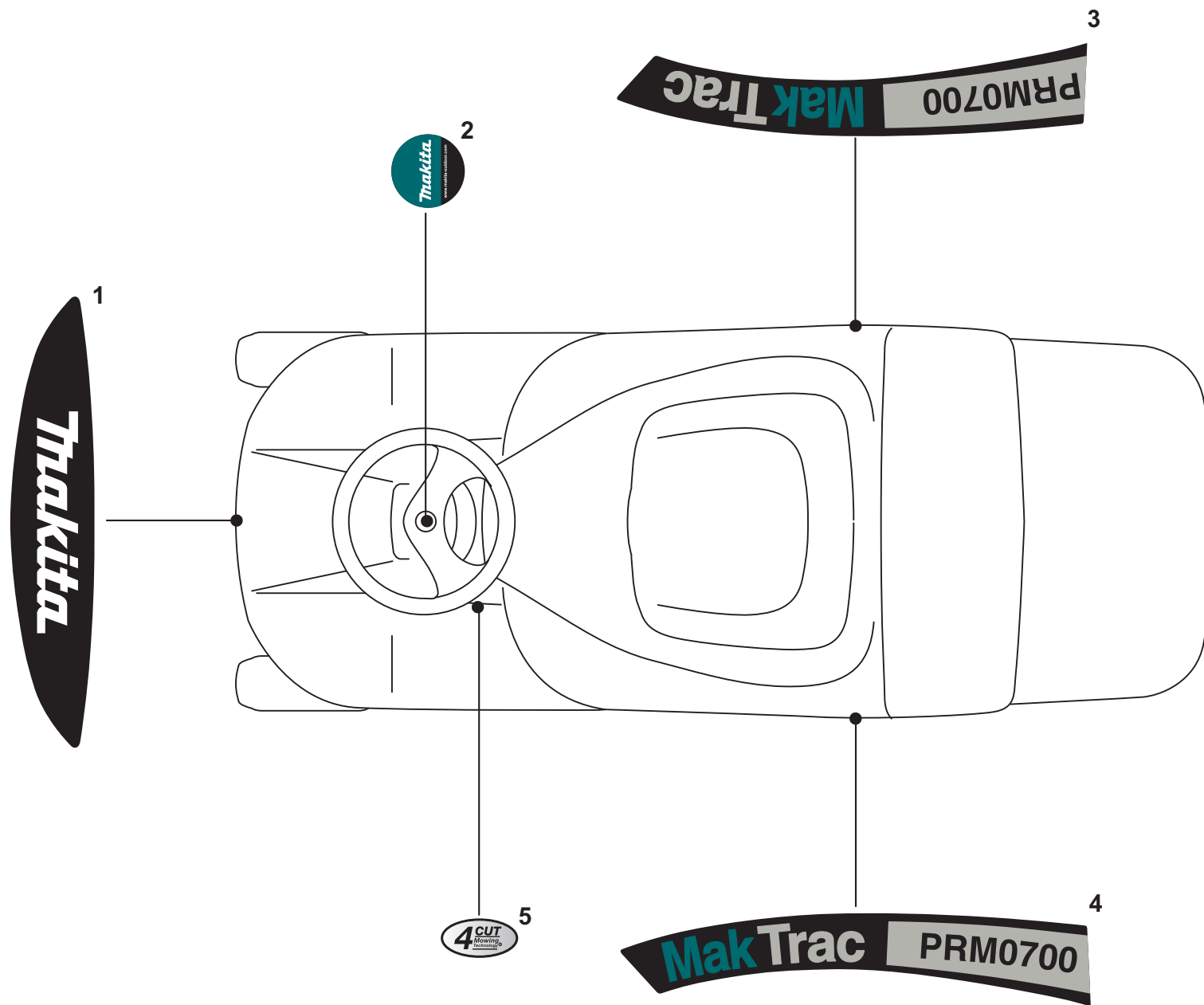

PRM0700 (2011)

14

AUFKLEBER  
LABELS  
ETIQUETTES  
ETIQUETA

Seite / Page	Pos.	PRM0700 (2011)	Teil-Nr. Part No. No. de pièce No. de pieza	Hinweise Notes Renseign. Nota	Bezeichnung	Spezifikation Specification	Description	Désignation	Denominación
14	1	1	664 362 531		SCHILD	MAKITA	LABEL	ETIQUETTE	ETIQUETA
14	2	1	664 361 486		SCHILD	MAKITA	LABEL	ETIQUETTE	ETIQUETA
14	3	1	664 362 532		SCHILD	PRM0700	LABEL	ETIQUETTE	ETIQUETA
14	4	1	664 362 533		SCHILD	PRM0700	LABEL	ETIQUETTE	ETIQUETA
14	5	1	664 999 576		SCHILD	4 CUT	LABEL	ETIQUETTE	ETIQUETA

	Zeichenerklärung	Key to symbols	Légende	Explicación de símbolos
=> 1999999 2000000 => 2003.04 => TI 2003/07 <b>Acc.</b> = { m <b>Corr.</b>	Produktion bis Serien-Nr. Neues Teil ab Serien-Nr. Neues Teil ab Jahr / Monat Siehe Technische Information Jahr / Nr. Zubehör (nicht im Lieferumfang) Keine Serienausführung, jedoch verwendbar Beinhaltet Positions-Nr. Meterware Druckfehlerberichtigung	Production to serial number New part from serial number New part from Year / Month See Technical Information Year / No. Accessories (not included in the delivery inventory) No standard execution, may be used Contains item number Sold by the meter Error correction	Production jusqu'à n° de série Nouvelle pièce à partir du n° de série Nouvelle pièce à partir de année / mois Voir information technique année / n° Accessoires (non compris dans la livraison) Aucune exécut. en série, cependant utilisable contient n° de numéro Au mètre Rectification d'erreurs	Producción hasta N° de serie Pieza nueva a partir de N° de serie Pieza nueva a partir de año / mes Véase inform. técnico año / N° Accesorios (no incluido en la extensión del suministro) No es de serie, pero sirve Contiene pos N° Por metro Fe de erratas
	Änderungen vorbehalten	Specifications subject to change without notice	Changements sans préavis	Mejoras constructivas sin previo aviso